



Product Range

16

For the Perfect Finish

Contract Flooring



Genesis

For the Perfect Finish



# Contents

- STAIR NOSINGS** - Performance, safety and style and some new innovative solutions for all floor surfaces
- FLEXIBLES** - Finishing profiles in P.V.C. for soft flooring applications
- ENTRANCE MATTING** - The complete range of matting and accessories to suit all aspects of installations
- TRANSITIONS, COVERS & RAMPS** - An extensive selection of profiles to solve those floor finishing problems
- EXPANSION JOINTS** - For all applications including structural joints and commercial grade covers
- EDGE PROTECTION** - Specifically designed for heavy traffic and commercial areas
- P.V.C. TRIM** - A huge range of quality P.V.C. finishing profiles perfect for ceramic tiles
- METAL TRIM & LISTELLO** - Aluminium and Stainless Steel profiles in many sizes and finishes
- TOOLS** - A comprehensive range of professional tools for any tiling task
- PPE** - Protection equipment for all industries to suit DIY and professionals
- BASIC TOOLS** - A focused range of tools providing a cost effective alternative
- SOFT FLOORING TOOLS** - A range of top quality focused tools for the soft flooring installer
- MARKETING** - Point of Sale, Display, Literature and Samples Systems helping to promote the Genesis range



## Nosing Insert Slip Resistance

Slip-resistance tests have been independently undertaken by Lucideon Ltd using the pendulum and inclined platform test.

### Inclined Platform Test DIN 51130:2010

	Operator 1 - Angle of Inclination	Operator 2 - Angle of Inclination
1	23.6°	22.3°
2	23.5°	21.0°
3	24.4°	22.7°

Average of Six Shod Results (Corrected): 22.9°

### Category: R11

The critical angle at which a test person reaches the limit of safe walking on an inclined plane is used as a measure of slip resistance.

### Pendulum Test BS 7976-2:2002

**PTV Average Dry Value: 66 PTV Average Wet Value: 54**

The energy absorbed by contact with the pre-set distance is read from a physical scale by a pointer that follows the overswing of the pendulum arm. 12 results are averaged to give the final pendulum number which is used to categorise the tile surface.

The UK slip resistance group recommends the following guidelines;

PTV	Slip Potential
0-24	High
25-35	Moderate
36+	Low

## LRV's – Clarification

Reflectance is the proportion of light that a surface reflects compared to the amount or volume of light that falls on the said surface. An LRV is a value given to a surface to identify the amount of light reflected. People with impaired vision can perceive light and dark, therefore LRV's are a suitable method to measure contrast between 2 different surfaces.

Note that dark, matt or textured surfaces absorb a large amount of light, therefore have low reflectance values, however a combination of one or all light, shiny or smooth surfaces reflect the majority of light and therefore have higher reflectance values.

In order to achieve a suitable contrast between different surfaces, ADM 2004 recommend at least a 30 point difference in the LRV's of the two contrasting surfaces.

## Genesis and Tredsafe® Stair Nosing Inserts Light Reflectance Values

Genesis Colour	LRV	RAL	Genesis Colour	LRV	RAL
01 White	79.9	9003	47 Yellow	55.7	1018
16 Black	4.5	9004	48 Cobalt Blue	9.2	5000
20 Brown	9.1	8014	52 Lime	30.4	6011
25 Beige	41.1	1001	109 Sky Blue	13.5	5015
27 Canvas	53.2	1013	113 Tangerine	N/A	2000
28 Green	6.3	6005	601 White	82.7	9003
30 Red	10.6	3031	616 Black	4.8	9004
43 Dolphin Grey	27.6	7042	643 Mid Grey	18.3	7000
44 Ice Grey	42.1	7001	647 Yellow	46.1	1012
46 Midnight Grey	12.8	7024			

Please note the RAL numbers in the above table is a guide only. Genesis do not manufacture to RAL numbers and cannot guarantee an exact match as there are a number of variables within the manufacturing process.

## Drilling Instructions

### Drill using Genesis countersunk drill bit

Start 75mm from each end and set all holes equally as indicated for single and double channel.

Length	No. of Holes
600 - 699	2
700 - 1099	3
1100 - 1399	4
1400 - 1799	5
1800 - 2099	6
2100 - 2499	7
2500 - 2799	8
2800 - 3200	9

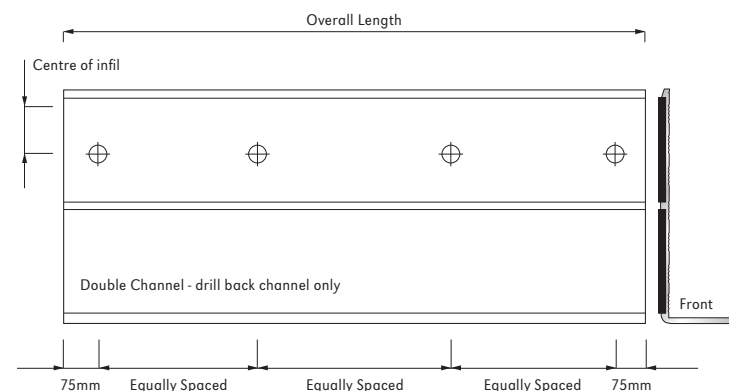
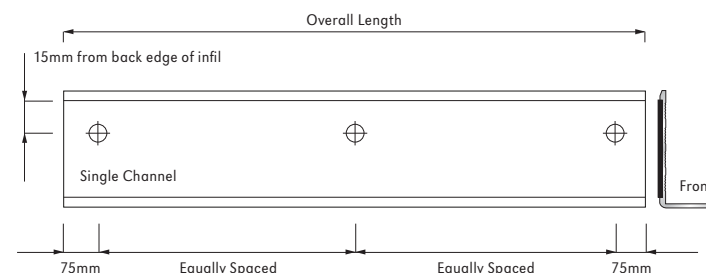
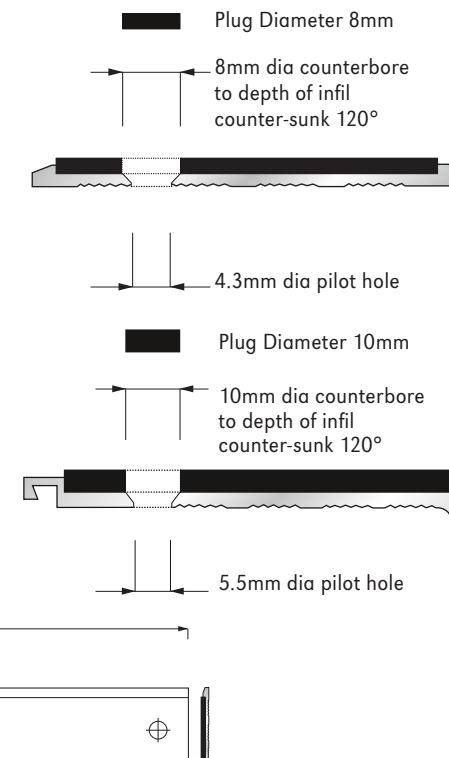

## Installation - Mechanical Fix



- 1** Prepare surface, it must be clean, smooth and free of debris.
- 2** Position the profile, check the fit and mark the drill holes.
- 3** Drill and Plug to suit the screw size.
- 4** Apply adhesive as per manufacturer's instructions.



- 5** Position onto step.
- 6** Mechanically fix.
- 7** Insert plug.
- 8** Remove protective film when applicable.

If fixing inserts separate follow steps 1 – 6, remove release paper from channel and position insert ends flush applying pressure towards the centre finishing with hand roller to ensure adhesion.

## Installation - Adhesive

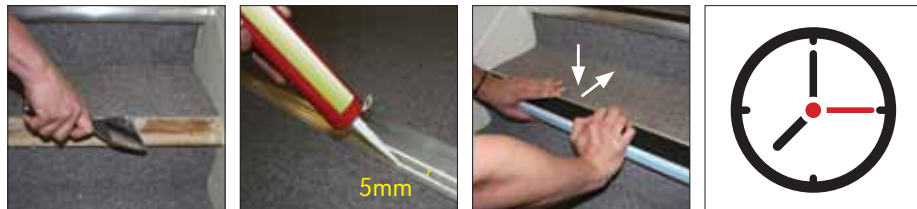

- 1** Prepare surface, it must be clean, smooth and free of debris.
- 2** Apply 5mm bead to the underside of the profile, 2 lines for Single and 3 for double channel.
- 3** Position, press and slide to ensure full bond.
- 4** Allow min. 1 hour after fixing. It is the contractor's responsibility to ensure the bond is secure before opening the area.

Installer must follow individual manufacturers guidelines

## Templates/Curves

Aluminium stair casings can be made to fit most irregular shapes and curves. However each curved step must be treated individually and a separate template made for each using card, felt or paper. Follow these three simple steps as an easy guide to the perfect edge.

### Step 1

Place the card or felt on top of the curve that requires a template and draw a line underneath with a felt pen or marker (see Figure 1) following the edge of the curve to create a smooth line.

Figure 1

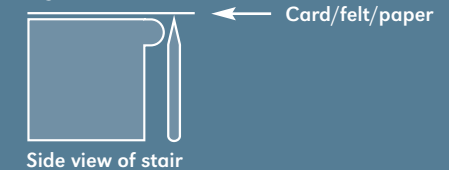

### Step 2

Cut the shape along the felt pen mark (Figure 2) and clearly indicate the top and front edge of the template.

Figure 2

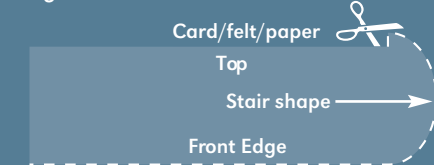

### Step 3

Clearly mark on the template, the customer name and reference, the profile required, the colour insert required and finally whether your curve is required drilled or undrilled (Figure 3).

Figure 3

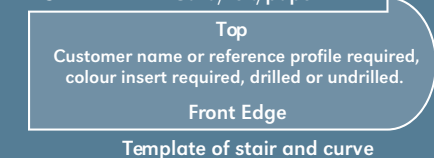

For assistance with any aspect of measuring or making templates please speak to Technical Services.

## Slimline Aluminium Nosings



## Code W x D (mm) Insert Option

Code	W x D (mm)	Insert Option
NSL01	56 x 32	01,16,20,25,27,28,30,43,44,46,47,48,52,109,113
NSL02	57 x 32	01,16,20,25,27,28,30,43,44,46,47,48,52,109,113
NSL03	57 x 40	01,16,20,25,27,28,30,43,44,46,47,48,52,109,113
NSL09	85 x 32	01,16,20,25,27,28,30,43,44,46,47,48,52,109
NSL10	85 x 32	01,16,20,25,27,28,30,43,44,46,47,48,52,109
NSL15	66 x 32	01,16,20,25,27,28,30,43,44,46,47,48,52,109,113
NSL16	66 x 32	01,16,20,25,27,28,30,43,44,46,47,48,52,109,113
NSL19	56 x 55	01,16,20,25,27,28,30,43,44,46,47,48,52,109,113
NSL20	57 x 55	01,16,20,25,27,28,30,43,44,46,47,48,52,109,113
NSL21	67 x 55	01,16,20,25,27,28,30,43,44,46,47,48,52,109,113
NSL23	68 x 33	16 3m lengths only
NSL25	69 x 40	01,16,20,25,27,28,30,43,44,46,47,48,52,109,113
NSL26	67 x 55	01,16,20,25,27,28,30,43,44,46,47,48,52,109,113
NSL27	69 x 55	01,16,20,25,27,28,30,43,44,46,47,48,52,109,113
NSL28	69 x 55	01,16,20,25,27,28,30,43,44,46,47,48,52,109,113

Available in 2.46m, 2.77m, 3.22m Standard Lengths.

### Infill

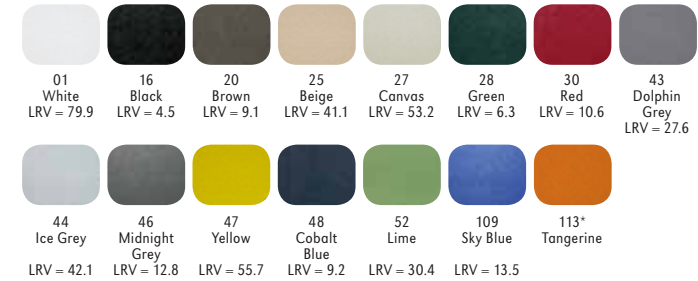

### Channel



### Anodising - Maximum length 3m

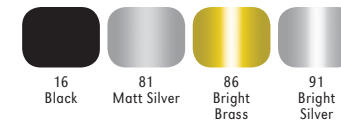

\*50mm only

## Heavy Duty Aluminium Nosings

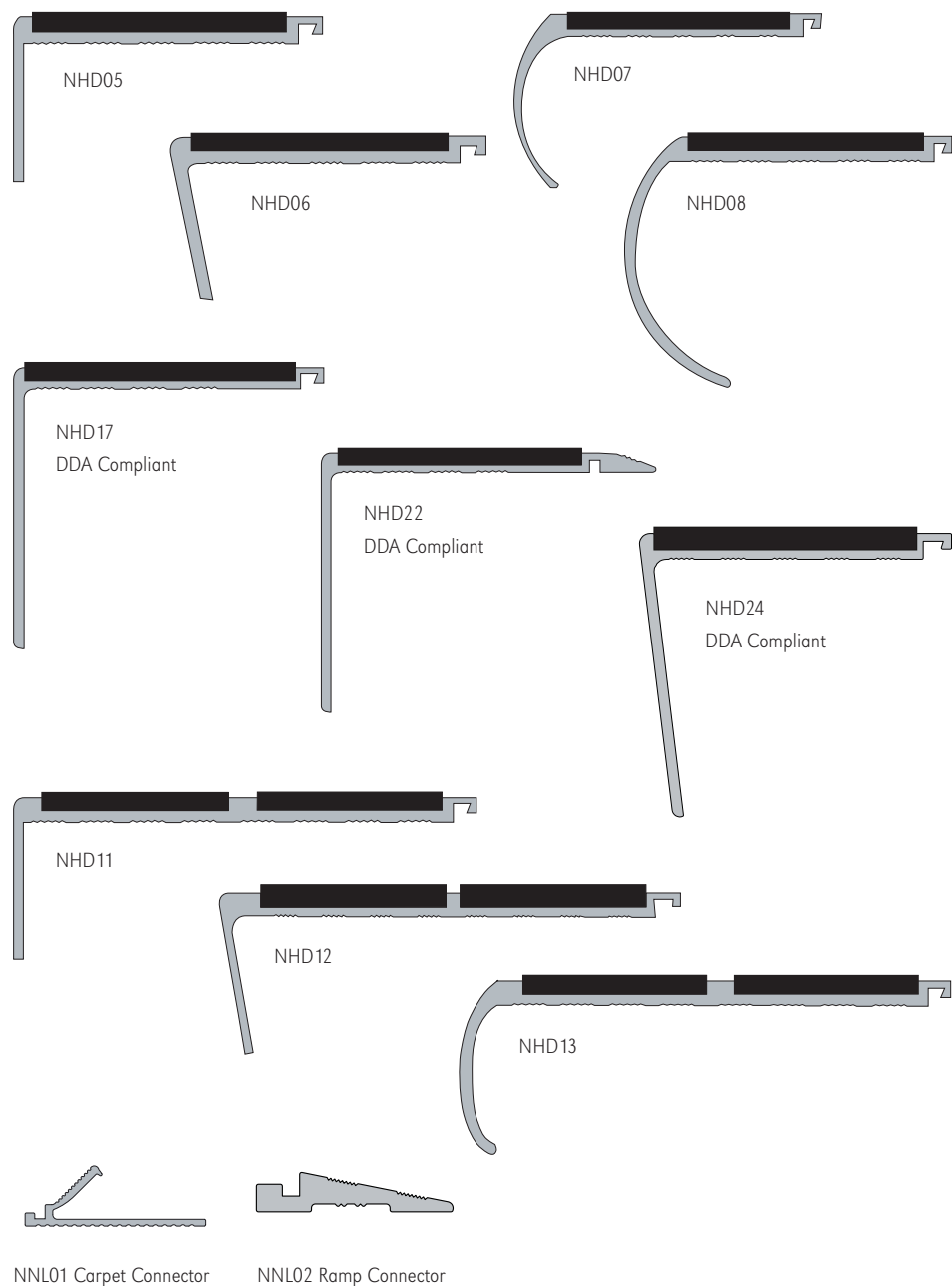

Code	W x D (mm)	Insert Option
NHD05	60 x 32	01,16,20,25,27,28,30,43,44,46,47,48,52,109,216,243,246
NHD06	63 x 32	01,16,20,25,27,28,30,43,44,46,47,48,52,109,216,243,246
NHD07	70 x 40	01,16,20,25,27,28,30,43,44,46,47,48,52,109,216,243,246
NHD08	71 x 55	01,16,20,25,27,28,30,43,44,46,47,48,52,109,216,243,246
NHD11	91 x 32	01,16,20,25,27,28,30,43,44,46,47,48,52,109,216,243,246
NHD12	93 x 32	01,16,20,25,27,28,30,43,44,46,47,48,52,109,216,243,246
NHD13	91 x 35	01,16,20,25,27,28,30,43,44,46,47,48,52,109,216,243,246
NHD17	60 x 55	01,16,20,25,27,28,30,43,44,46,47,48,52,109,216,243,246
NHD22	72 x 55	01,16,20,25,27,28,30,43,44,46,47,48,52,109,216,243,246
NHD24	60 x 55	01,16,20,25,27,28,30,43,44,46,47,48,52,109,216,243,246
NNL01	40 x 10	80
NNL02	20 x 3.5	80

Available in 2.46m, 2.77m, 3.22m Standard Lengths. Pips are not available with External Grade Inserts due to material composition.

Inserts (external resin infill available, details on page 9)  
 (external Tredsafe® available, details on page 11)

### Infill



### Anodising - Maximum length 3m

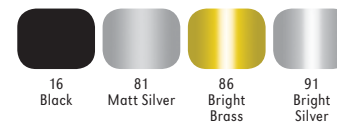

## Heavy Duty Aluminium External Nosings

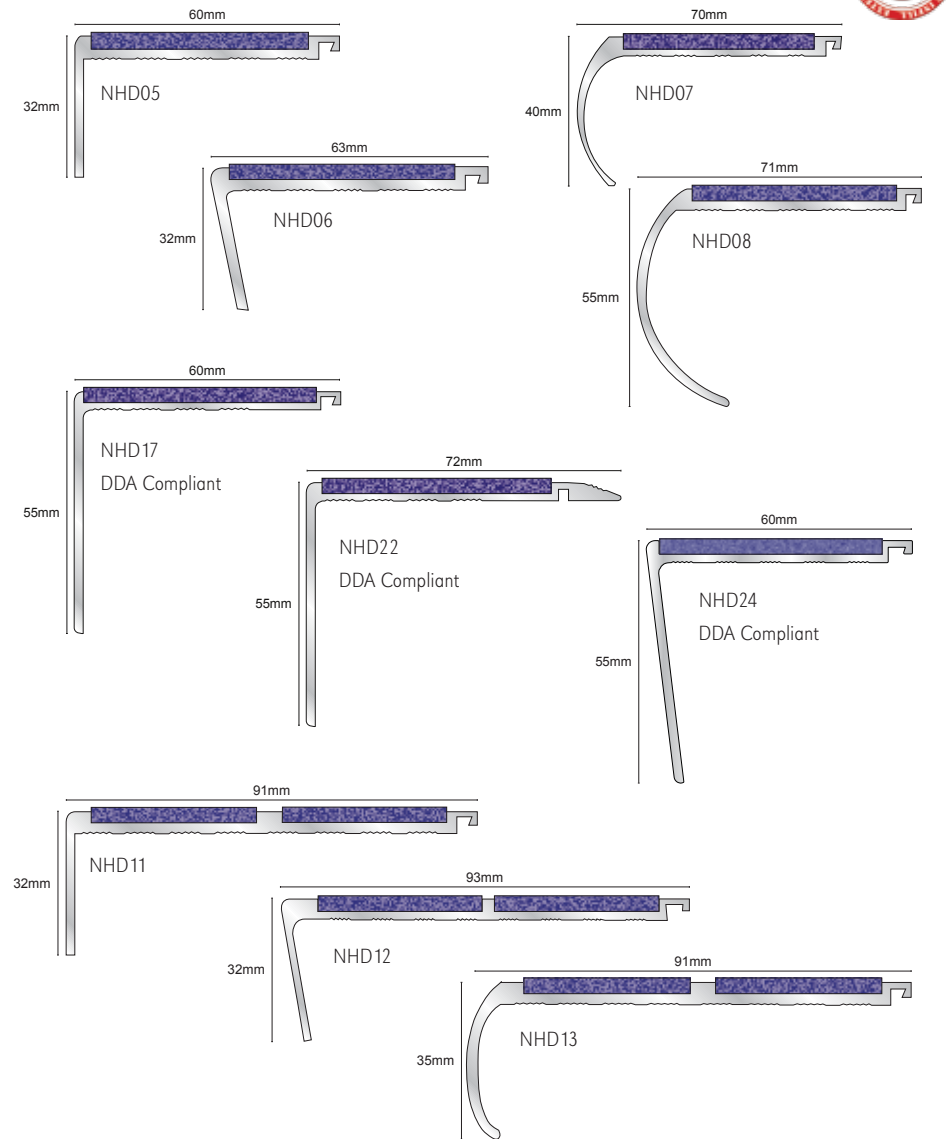

Code	W x D (mm)	External Insert
NHD05	60 x 32	501,516,520,547,548
NHD06	63 x 32	501,516,520,547,548
NHD07	70 x 40	501,516,520,547,548
NHD08	71 x 55	501,516,520,547,548
NHD11	91 x 32	501,516,520,547,548
NHD12	93 x 32	501,516,520,547,548
NHD13	91 x 35	501,516,520,547,548
NHD17	60 x 55	501,516,520,547,548
NHD22	72 x 55	501,516,520,547,548
NHD24	60 x 55	501,516,520,547,548
NNL01	40 x 10	
NNL02	20 x 3.5	

Lengths made to order. Minimum orders may apply

The range uses a unique carborinium composite insert that is extremely hard wearing and durable. It exceeds all health and safety requirements for wet and dry slip potential.

Each length is made to order with the insert composition applied into the channel to suit individual requirements.

### External Infill

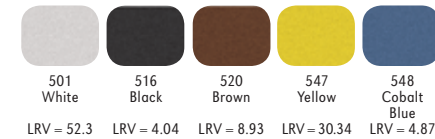

### Channel



### Anodising - Maximum length 3m

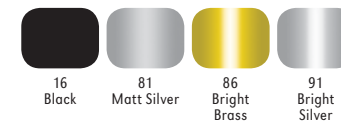

**Aluminator™ Heavy Duty Nosings**

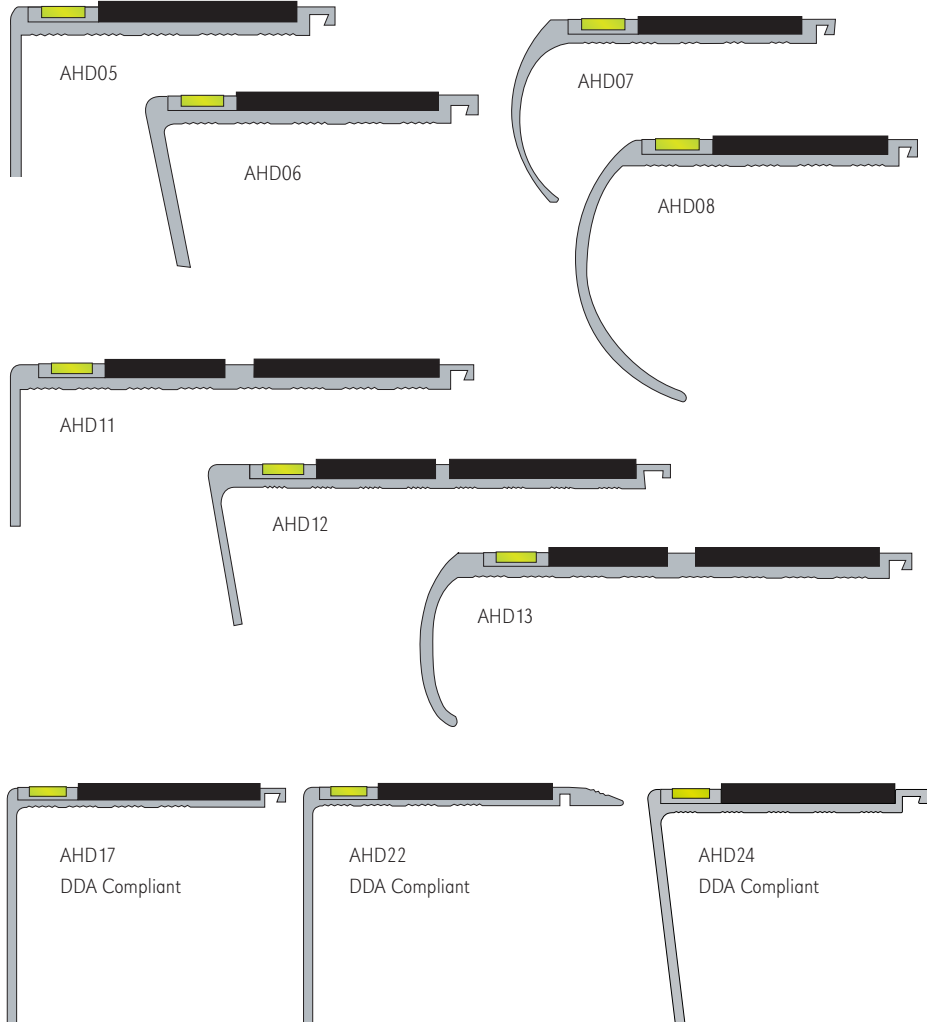

**Code W x D (mm) Insert Option**

Code	W x D (mm)	Insert Option
AHD05	60 x 32	01,16,20,25,27,28,30,43,44,46,47,48,52,109
AHD06	63 x 32	01,16,20,25,27,28,30,43,44,46,47,48,52,109
AHD07	70 x 40	01,16,20,25,27,28,30,43,44,46,47,48,52,109
AHD08	71 x 55	01,16,20,25,27,28,30,43,44,46,47,48,52,109
AHD11	91 x 32	01,16,20,25,27,28,30,43,44,46,47,48,52,109
AHD12	93 x 32	01,16,20,25,27,28,30,43,44,46,47,48,52,109
AHD13	91 x 35	01,16,20,25,27,28,30,43,44,46,47,48,52,109
AHD17	60 x 55	01,16,20,25,27,28,30,43,44,46,47,48,52,109
AHD22	72 x 55	01,16,20,25,27,28,30,43,44,46,47,48,52,109
AHD24	60 x 55	01,16,20,25,27,28,30,43,44,46,47,48,52,109

Available in 2.46m, 2.77m, 3.22m Standard Lengths

**Infill**

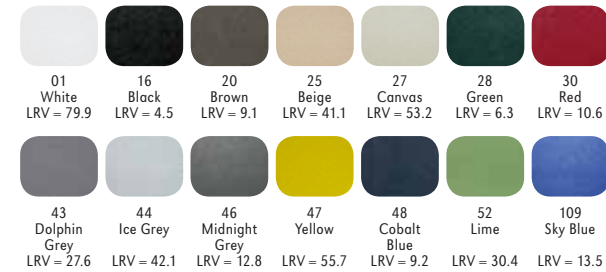

**Channel**



**Anodising - Maximum length 3m**



An alternative range of anodising and powder coated options are also available in addition to the standard options above.



## Tredsafe® External Insert

**NEW**

	Code	W x D (mm)	Insert Option
 Slimline	NSL01	56 x 32	601,616,643,647
	NSL02	57 x 32	601,616,643,647
	NSL03	57 x 40	601,616,643,647
	NSL09	85 x 32	601,616,643,647
	NSL10	85 x 32	601,616,643,647
	NSL15	66 x 32	601,616,643,647
	NSL16	66 x 32	601,616,643,647
	NSL19	56 x 55	601,616,643,647
	NSL20	57 x 55	601,616,643,647
	NSL21	67 x 55	601,616,643,647
	NSL25	69 x 40	601,616,643,647
	NSL26	67 x 55	601,616,643,647
	NSL27	69 x 55	601,616,643,647
	NSL28	69 x 55	601,616,643,647

Available in 2.46m, 2.77m, 3.22m Standard Lengths

Profile designs shown on page 4

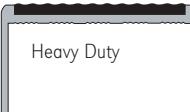
	Code	W x D (mm)	Insert Option
 Heavy Duty	NHD05	60 x 32	601,616,643,647
	NHD06	63 x 32	601,616,643,647
	NHD07	70 x 40	601,616,643,647
	NHD08	71 x 55	601,616,643,647
	NHD11	91 x 32	601,616,643,647
	NHD12	93 x 32	601,616,643,647
	NHD13	91 x 35	601,616,643,647
	NHD17	60 x 55	601,616,643,647
	NHD22	72 x 55	601,616,643,647
	NHD24	60 x 55	601,616,643,647

Available in 2.46m, 2.77m, 3.22m Standard Lengths

Profile designs shown on page 16

### Finishes



601 White	616 Black	643 Dolphin Grey	647 Yellow
LRV = 82.7	LRV = 4.8	LRV = 18.2	LRV = 46.1

## Tredsafe® External Insert Continued

**NEW**

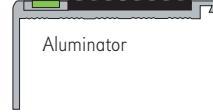
	Code	W x D (mm)	Insert Option
 Aluminator	AHD05	60 x 32	601,616,643,647
	AHD06	63 x 32	601,616,643,647
	AHD07	70 x 40	601,616,643,647
	AHD08	71 x 55	601,616,643,647
	AHD11	91 x 32	601,616,643,647
	AHD12	93 x 32	601,616,643,647
	AHD13	91 x 35	601,616,643,647
	AHD17	60 x 55	601,616,643,647
	AHD22	72 x 55	601,616,643,647
	AHD24	60 x 55	601,616,643,647

Available in 2.46m, 2.77m, 3.22m Standard Lengths

Profile designs shown on page 10

## Inserts

### NISL38

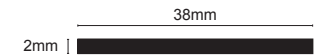

Insert	Type	Size (mm)	Colour options	Fits	External
NISL38	Standard	38 x 2	01,16,20,25,27,28,30,43,44,46,47,48,52,109	NSL Twin Channel	No

### NISL50



Insert	Type	Size (mm)	Colour options	Fits	External
NISL50	Standard	50 x 2	01,16,20,25,27,28,30,43,44,46,47,48,52,109,113	NSL Single Channel	No

### NIHD38



Insert	Type	Size (mm)	Colour options	Fits	External
NIHD38	Standard	38 x 3.5	01,16,20,25,27,28,30,43,44,46,47,48,52,109	NHD Twin Channel	No

### NIHD50

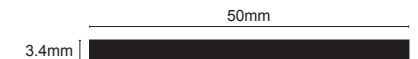

Insert	Type	Size (mm)	Colour options	Fits	External
NIHD50	Standard	50 x 3.5	01,16,20,25,27,28,30,43,44,46,47,48,52,109	NHD Single Channel	No

## Inserts

### NIFL50



Insert	Type	Size (mm)	Colour options	Fits	External
NIFL50	Grooved	50 x 3.5	216,243,246	NHD Single Channel	No

### NITR38

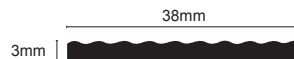

Insert	Type	Size (mm)	Colour options	Fits	External
NITR38	Tredsafe	38 x 3	601,616,643,647	NSL, NHD Twin Channel	Yes

### NITR50

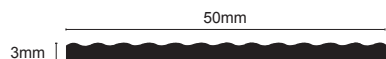

Insert	Type	Size (mm)	Colour options	Fits	External
NITR50	Tredsafe	50 x 3	601,616,643,647	NSL, NHD Single Channel	Yes

## Stair Edge Trim Pre-Formed / Landing Strip

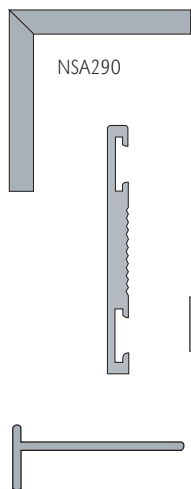

Code	D (mm)	Length (mm)	Finish	Style	Box Qty
NSA290	42	350	16,20,46,48	Straight	10
NSA290	42	350	80	Straight	10
NSA283	42	350	16,20,46,48	Rakeback	10
NSA283	42	350	80	Rakeback	10
NTL1	42	2500	16,20,46,48		10
NTL1	42	2500	80		10

Finish 16,20,46 and 48 are P.V.C. Finish 80 is Aluminium

Code	D (mm)	Pack Qty
NTAB1	4.5 / 7	Dual Height 20

## Hard Nose P.V.C

### Heavy Duty

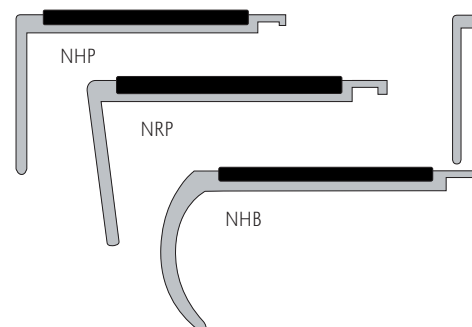

### Slimline

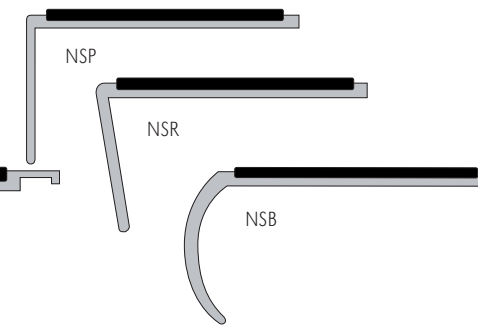

### Heavy Duty

Code	D (mm)	Channel Finish	Infill Finish
NHP	65 x 33	16,20,46,48	01,16,20,25,27,28,30,43,44,46,47,48,52,109,216 <sup>f</sup> ,243 <sup>f</sup> ,246 <sup>f</sup>
NRP	65 x 33	16,20,46,48	01,16,20,25,27,28,30,43,44,46,47,48,52,109,216 <sup>f</sup> ,243 <sup>f</sup> ,246 <sup>f</sup>
NHB	65 x 32	16,20,46,48	01,16,20,25,27,28,30,43,44,46,47,48,52,109,216 <sup>f</sup> ,243 <sup>f</sup> ,246 <sup>f</sup>

### Slimline

NSP	60 x 31	16,20,46,48	01,16,20,25,27,28,30,43,44,46,47,48,52,109
NSR	59 x 31	16,20,46,48	01,16,20,25,27,28,30,43,44,46,47,48,52,109
NSB	60 x 31	16,20,46,48	01,16,20,25,27,28,30,43,44,46,47,48,52,109

Available in 3.22m lengths

## Heavy Duty Ceramic Tile-In Nosing

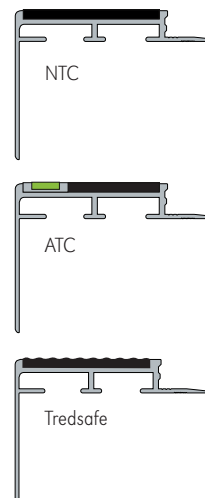

Code	W x D (mm)	Insert Option
NTC10	74 x 10	01,16,20,25,27,28,30,43,44,46,47,48,52,109,216
NTC12	74 x 12.5	01,16,20,25,27,28,30,43,44,46,47,48,52,109,243
<b>Aluminator™</b>		
ATC10	74 x 10	01,16,20,25,27,28,30,43,44,46,47,48,52,109
ATC12	74 x 12.5	01,16,20,25,27,28,30,43,44,46,47,48,52,109
<b>Tredsafe</b>		
NTC10	74 x 10	601,616,643,647
NTC12	74 x 12.5	601,616,643,647

Available in 3.22m Standard Lengths.

## External Application Retro Nosings with Silicone Carbide Insert

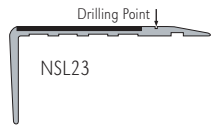

Code	W x D (mm)	Length (m)	Infill Finish	Box Qty
NSL23300	68 x 33	3	16	10
AHD23300	68 x 33	3	16 (with Aluminator Strip)	10

No pips available

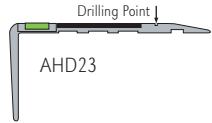

**Cutting & Drilling**  
 Cutting Surcharge 5%. Drilling Surcharge 10%

## GenStep Tread



### Square

Code	W x D (mm)	Length (m)	Finish	Box Qty
NTSQ				
NTSQ126	12 x 6	2.7	01,16,20,43,47	10
NTSQ256	25 x 6	2.7	01,16,20,43,47	10
NTSQ386	38 x 6	2.7	01,16,20,43,47	10
NTSQ506	50 x 6	2.7	01,16,20,43,47	10
NTSQ636	63 x 6	2.7	01,16,20,43,47	10
NTSQ756	75 x 6	2.7	01,16,20,43,47	10



### Dovetail

Code	W x D (mm)	Length (m)	Finish	Box Qty
NTRD				
NTCH126	12 x 6	2.7	01,16,20,43,47	10
NTCH256	25 x 6	2.7	01,16,20,43,47	10
NTCH386	38 x 6	2.7	01,16,20,43,47	10
NTCH506	50 x 6	2.7	01,16,20,43,47	10
NTCH636	63 x 6	2.7	01,16,20,43,47	10
NTCH756	75 x 6	2.7	01,16,20,43,47	10



### Round

Code	W x D (mm)	Length (m)	Finish	Box Qty
NTCH				
NTRD126	12 x 6	2.7	01,16,20,43,47	10
NTRD256	25 x 6	2.7	01,16,20,43,47	10
NTRD386	38 x 6	2.7	01,16,20,43,47	10
NTRD506	50 x 6	2.7	01,16,20,43,47	10
NTRD636	63 x 6	2.7	01,16,20,43,47	10
NTRD756	75 x 6	2.7	01,16,20,43,47	10



### Disc

Code	W x D (mm)	Length (m)	Finish	Box Qty
NTDC				
NTDC256	6	25	01,16,20,43,47	10
NTDC386	6	38	01,16,20,43,47	10
NTDC506	6	50	01,16,20,43,47	10
NTDC258	8	25	01,16,20,43,47	10
NTDC388	8	38	01,16,20,43,47	10
NTDC508	8	50	01,16,20,43,47	10

12% drilling surcharge. 5% cutting surcharge. No pips available

## NTEX Nosings

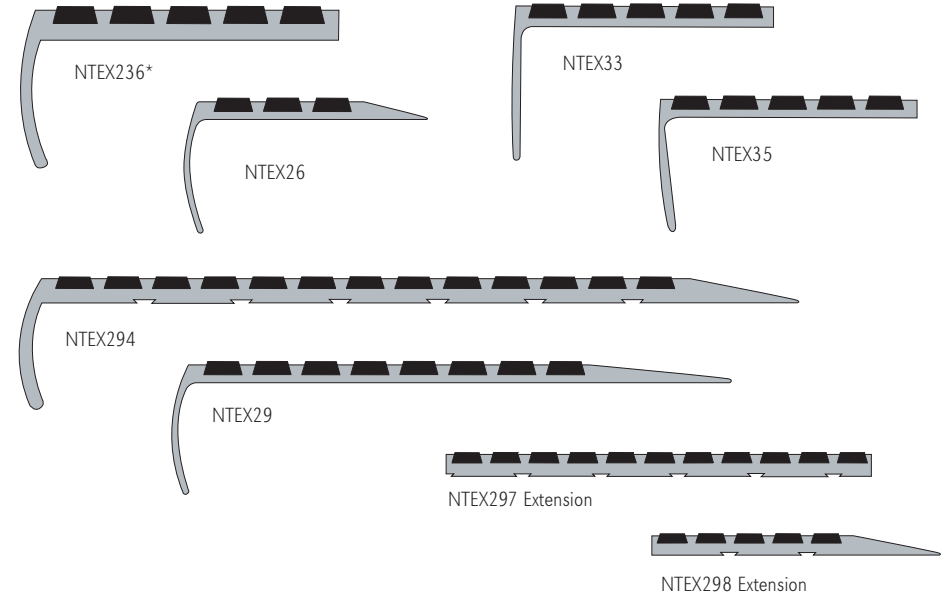

Code	Width (mm)	Depth (mm)	Infill Finish
NTEX33	73	38	Available in all Infill colours
NTEX26	65	32	Available in all Infill colours
NTEX35	73	32	Available in all Infill colours
NTEX29	152	32	Available in all Infill colours
NTEX294	222	30	Available in all Infill colours
NTEX236*	76	31	Available in all Infill colours
NTEX297	157	7	Available in all Infill colours
NTEX298	106	7	Available in all Infill colours

Bespoke Production - Average 7 days from order. No pips available. Minimum orders may apply

## Definer

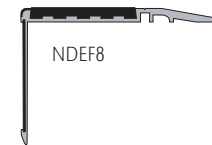

Code	Width (mm)	Depth (mm)	Riser Colours
NDEF8	105	65	01,47
NDEF10	105	65	01,47

Available Infill Finishes  
 300,305,310,315,320,325,330,335,340,345,350,355,360,365,370,375,380,385,390  
 Bespoke Production - Average 7 days from order. No pips available. Minimum orders may apply

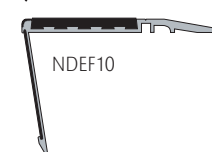

NTEX and NDEF max. length 3m - cut to size upon request

## Genstep+

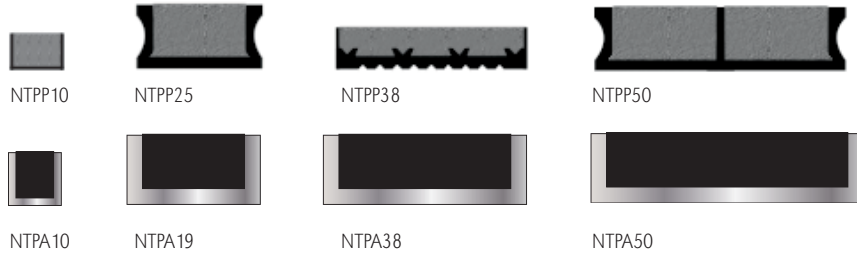

Code	Width (mm)	Depth (mm)	Infill Finish
NTPP10	10	7	Available in all Infill colours
NTPP25	25	12.5	Available in all Infill colours
NTPP38	38	8	Available in all Infill colours
NTPP50	50	12.5	Available in all Infill colours
NTPA10	9.5	9.5	Available in all Infill colours
NTPA19	19	12.5	Available in all Infill colours
NTPA38	38	12.5	Available in all Infill colours
NTPA50	50	12.5	Available in all Infill colours
NTPD34	34	7	Available in all Infill colours
NTPD55	55	7	Available in all Infill colours

Bespoke Production - Average 7 days from order. No pips available. Minimum orders may apply

## Rubber Stud Tactiles

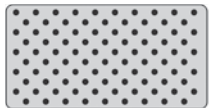

Code	W x L (mm)	Finish	Box Qty
R4250	800 x 420	01	6
R4251	800 x 420	43	6
R4252	800 x 420	46	6

## Flexible P.V.C. Nosings

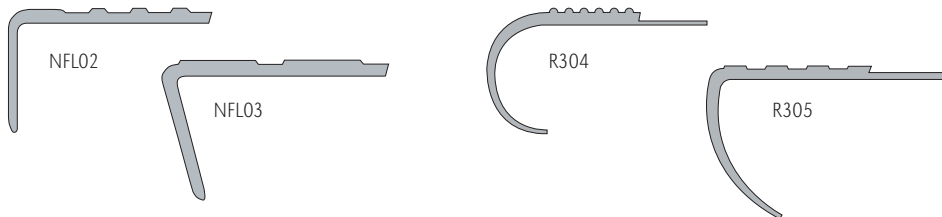

Code	W x D (mm)	Length (m)	Finish	Box Qty
NFL02	50 x 50	3.22	16	10
NFL03	60 x 37	3.22	16	10
R3041	45 x 35	3.00	16	10
R3043	45 x 35	3.00	43	10
R3051	40 x 35	3.00	16	10
R3053	40 x 35	3.00	43	10

## Fluted Metal Tactile Studs

**NEW**



Code	Ø (mm)	Type	Description	Finish	Box Qty
FTSSA25	25	Self Adhesive	Stainless Steel Anti-Slip Tactile	01,16,47	20
FTNYA25	25	Self Adhesive	Sustamid Nylon Anti-slip Tactile	01,16,47	20
FTSSA25	25	Self Adhesive	Stainless Steel Circle Tactile	84	20
FTNYA25	25	Self Adhesive	Sustamid Nylon Circle Tactile	16	20
FTSCA25	25	Self Adhesive	Stainless Steel Crosshatch Tactile	84	20
FTNCA25	25	Self Adhesive	Sustamid Nylon Crosshatch Tactile	16	20
FTSSD25	25	Shanked	Stainless Steel Anti-Slip Tactile	01,16,47	20
FTNYD25	25	Shanked	Sustamid Nylon Anti-slip Tactile	01,16,47	20
FTSCD25	25	Shanked	Stainless Steel Circle Tactile	84	20
FTNCD25	25	Shanked	Sustamid Nylon Circle Tactile	16	20
FTSCD25	25	Shanked	Stainless Steel Crosshatch Tactile	84	20
FTNHD25	25	Shanked	Sustamid Nylon Crosshatch Tactile	16	20
FTCD280	25	Shanked Strip	280mm stainless Steel Corduroy trim	01,16,47	20
FTCA280	25	Self Adhesive Strip	280mm stainless Steel Corduroy trim	01,16,47	20
FASD25	25	Self Adhesive	Coarse Anti-Slip discs	01,16,47	250
FASD35	35	Self Adhesive	Coarse Anti-Slip discs	01,16,47	250



## Aluminium Self Adhesive Retro-Fit



Code	W x D (mm)	Length (m)	Finish	Box Qty
NAS207	30 x 20	2.7	40	10
NAS207	30 x 20	2.7	81,83	10
NAS209 <b>NEW</b>	30 x 20	0.9	40	10
NAS209 <b>NEW</b>	30 x 20	0.9	81,83	10
NAS107	25 x 10	2.7	40	10
NAS107	25 x 10	2.7	81,83	10
NAS109 <b>NEW</b>	25 x 10	0.9	40	10
NAS109 <b>NEW</b>	25 x 10	0.9	81,83	10

## Aluminium Retro-Fit

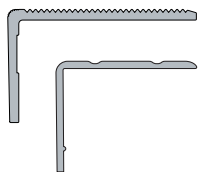

Code	W x D (mm)	Length (m)	Finish	Box Qty
NRA50	50 x 30	2.77	80	10
NRA258	24 x 19	2.8	81,83	20

## Aluminium Nosing with Black Rubber Insert

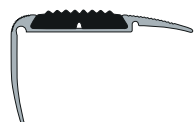

Code	W x D (mm)	Length (m)	Finish	Box Qty
NRE05	54 x 30	2.77	81	10

## Aluminium Tile-In



Code	W x D (mm)	Length (m)	Finish	Box Qty
NLM103	26 x 10	3	81	10
NLM123	26 x 12	3	81	10

Aluminium Tile-In **Aluminator™**

Code	D (mm)	Length (m)	Finish	Box Qty
ALM106	10.5	2.6	81	10
ALM126	12.5	2.6	81	10

## Aluminium Formable 2 in 1

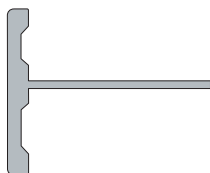

Code	W x D (mm)	Length (m)	Finish	Box Qty
NFA125	3 x 10/12	2.6	81	20
NFA125	3 x 10/12	2.6	91	20

## Aluminium Tile-In Bullnose

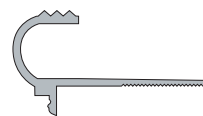

Code	D (mm)	Length (m)	Finish	Box Qty
NAT105	10	2.6	81	20
NAT105	10	2.6	91	20
NAT125	12	2.6	81	20
NAT125	12	2.6	91	20

## Aluminium Stair Grip + PVC Top



Code	W x D (mm)	Length (m)	Finish	Box Qty
NIB106	30 x 10	2.6	16,35	10
NIB126	30 x 12	2.6	16,35	10

## PVC End Caps for Aluminium Stair Grip + PVC Top

Code	Description	Finish	Pack Qty
NUC102	Pair of universal end caps	16,35	2

## Aluminium Tile-In with Carbide Insert



Code	D (mm)	Length (m)	Finish	Box Qty
NLC106	10	2.6	81	10
NLC126	12.5	2.6	81	10

## Stainless Steel Tile-In Nosing



Code	W x D (mm)	Length (m)	Finish	Box Qty
NSS106	10	2.6	84	10
NSS126	12	2.6	84	10

## Aluminium Tile-In Step Edge

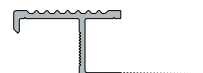

Code	W x D (mm)	Length (m)	Finish	Box Qty
NLT108	19 x 10	2.8	81	10

P.V.C. Flexible Sit On Skirting

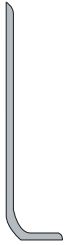

Code	H x D (mm)	Length (m)	Finish	Box Qty
KSO75	75 x 17	2	16	40
KSO100	100 x 20	2	16,43,46	30
KSO1015	100 x 20	15 (coil)	16,43	1
KSO150	150 x 20	2	16,43	20

P.V.C. Flexible Set In Skirting



Code	H x D (mm)	Length (m)	Finish	Box Qty
KSI100	100 x 50	2	16,43,46	20

P.V.C. Cove Former

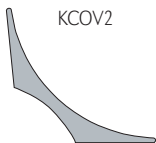

Code	W x D (mm)	Length (m)	Finish	Box Qty
KCOV1	38 x 38	2	16	30
KCOV2	20 x 20	2	16	30
KCOV3	32 x 32	2	16	30

P.V.C. Dim Strip



RDIM20



RDIM45

Code	W x D (mm)	Length (m)	Finish	Box Qty
RDIM20	26 x 2	15	16	10
RDIM25	26 x 2.5	15	16	10
RDIM45	36 x 4.5	2	16	40
RDIM60	40 x 6	2	16	20

P.V.C. Capping Strip



Code	W x D (mm)	Length (m)	Finish	Box Qty
KCS01	40 x 2	2	01,16,43	40
KCS012	40 x 2	20	01,16	3

P.V.C. Edge Cap Strip

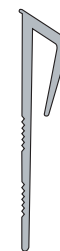

Code	W x D (mm)	Length (m)	Finish	Box Qty
KCS02	39.5 x 1.5	2	01,16	40
KCS022	39.5 x 1.5	20	01,16,43	3

## Romat Fluted Rubber



Code	Height (mm)	Finish	Box Qty
R8950	12	16	m <sup>2</sup>
R8951	17	16	m <sup>2</sup>
R8952	22	16	m <sup>2</sup>

## Rubber Grating



Code	Height (mm)	Finish	Size	Box Qty
R760*	12.5	16	1.5 x 1m	1
R752	12	16	1.5 x 0.9m	1

\*Art 8761 connector available

## Reversible fluted rubber

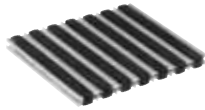

Code	Height (mm)	Finish	Size	Box Qty
R8030	18	16	m <sup>2</sup>	m <sup>2</sup>
R8031	12	16	m <sup>2</sup>	m <sup>2</sup>

## Romat Entrance Matting - Loop Pile and Polyamid

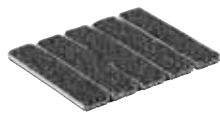

Code	Height (mm)	Finish	Box Qty
R8900	12	Anthracite	m <sup>2</sup>
R8901	12	Grey	m <sup>2</sup>
R8910	17	Anthracite	m <sup>2</sup>
R8911	17	Grey	m <sup>2</sup>
R8913	17	Sisal Shade	m <sup>2</sup>
R8920	22	Anthracite	m <sup>2</sup>
R8921	22	Grey	m <sup>2</sup>
R8923	22	Sisal Shade	m <sup>2</sup>

Code	Height (mm)	Finish	Box Qty
R8930*	12	Anthracite	m <sup>2</sup>
R8931*	12	Blue	m <sup>2</sup>

\*Polyamid

## Reversible Superior insert

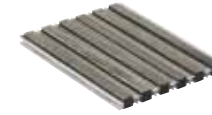

Code	Height (mm)	Finish	Box Qty
R8000	18	Grey	m <sup>2</sup>
R8016	18	Black	m <sup>2</sup>
R8002	12	Grey	m <sup>2</sup>
R8003	12	Black	m <sup>2</sup>

## Roclean Logo



Code	Height (mm)	Finish	Size	Box Qty
R8821	8.5	to order	85 x 150cm	1
R8822	8.5	to order	115 x 180cm	1

## Roclean



Code	Height (mm)	Finish	Size	Box Qty
R8840	10	Steel Grey	85 x 150cm	1
R8841	10	Dark Brown	85 x 150cm	1
R8845	10	Steel Grey	115 x 180cm	1
R8846	10	Dark Brown	115 x 180cm	1

## Bevelled Access Profile Aluminium



R6114

Code	Height (mm)	Length (m)	Finish	Box Qty
R6114*	15	4	Silver	1
R6115*	20	3	Silver	1

## Matwell Frame 17-23mm

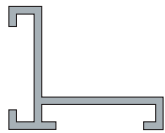

Code	Length (m)	Finish	Box Qty
R6100*	4	Silver	1
R6101*	4	Brass	1

## Matwell Frame 13mm

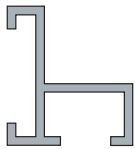

Code	Length (m)	Finish	Box Qty*
R6113*	4	Silver	1

## Feet for Sealing



Code	Description	Finish	Box Qty
R16103	Pack of 8 feet for setting	Brass	1

## Connector Angles



Code	Description	Finish	Box Qty
R16104	Pack of 4 corner angles for frame	Silver	1

\*10% Surcharge to cut to size with mitres

## Self Adhesive



TAS



CAS40



CAS25

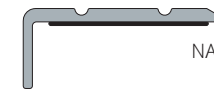

NAS



TAV

Code	W x D (mm)	Length (m)	Finish	Box Qty
TAS157	50 x 15	2.7	40	10
TAS157	50 x 15	2.7	81,83	10
TAS159 <b>NEW</b>	50 x 15	0.9	40	10
TAS159 <b>NEW</b>	50 x 15	0.9	81,83	10
TAS107	43 x 10	2.7	40	10
TAS107	43 x 10	2.7	81,83,89	10
TAS109 <b>NEW</b>	43 x 10	0.9	40	10
TAS109 <b>NEW</b>	43 x 10	0.9	81,83,89	10
CAS407	40 x 3	2.7	39,40,41	10
CAS407	40 x 3	2.7	81,83,89	10
CAS409 <b>NEW</b>	40 x 3	0.9	40,41	10
CAS409 <b>NEW</b>	40 x 3	0.9	81,83,89	10
CAS257	25 x 3	2.7	81,83	10
CAS259 <b>NEW</b>	25 x 3	0.9	81,83	10
NAS207	30 x 20	2.7	40	10
NAS207	30 x 20	2.7	81,83	10
NAS209 <b>NEW</b>	30 x 20	0.9	40	10
NAS209 <b>NEW</b>	30 x 20	0.9	81,83	10
NAS107	25 x 10	2.7	40	10
NAS107	25 x 10	2.7	81,83	10
NAS109 <b>NEW</b>	25 x 10	0.9	40	10
NAS109 <b>NEW</b>	25 x 10	0.9	81,83	10
TAV257	30 x 2.5	2.7	81,83	10
TAV259 <b>NEW</b>	30 x 2.5	0.9	81,83	10

## Aluminium Tile to Carpet Top

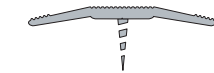

Code	W x D (mm)	Length (m)	Finish	Box Qty
TCA159	40 x 3	0.92	81,83	20
TCA159	40 x 3	0.92	87,91	20
TCA158	40 x 3	2.8	81	20

## Aluminium Tile to Carpet Top & Base Sets

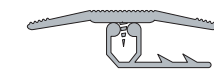

TTB



TBA

Code	W x D (mm)	Length (m)	Finish	Box Qty
TTB159	40 x 10	0.92	81,83	10
TTB159	40 x 10	0.92	87,91	10
TBA109	25 x 10	0.92	80	20
TBA108	25 x 10	2.8	80	20



### Brushed Stainless Cover



Code	W (mm)	Length (m)	Description	Box Qty
R1060	30	2.7	Pre-drilled	40
R1063	40	2.7	Pre-drilled	40
R1064	50	2.7	Pre-drilled	40
R2060	30	2.7	Self Adhesive	20

### Fast Fit Ramp System

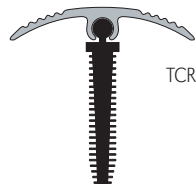

Code	W (mm)	Length (m)	Finish	Box Qty
TCR409	40	0.92	39,40,41,87,91,93,132,134	20
TCR409	40	0.92	81,83,85	20
TCR405	40	1.85	39,40,41,93,132,134	20
TCR405	40	1.85	81,83,85	20
TCG109	25	0.92	80	20
TCC109	25	0.92	80	20
TTG409	40	0.92	87,91	20



### Fast Fit Slimline

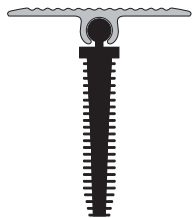

Code	W (mm)	Length (m)	Finish	Box Qty
TCS409	40	0.92	40,41,93,132,134	20
TCS409	40	0.92	81,83,85	20
TCS405	40	1.85	40,41,93,132,134	20
TCS405	40	1.85	81,83,85	20
TCG109	25	0.92	80	20
TCC109	25	0.92	80	20

### Aluminium Z-Bar Carpet Lock

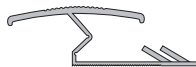

Code	W x D (mm)	Length (m)	Finish	Box Qty
TGA909	30 x 9	0.9	81,83	45
TGA909	30 x 9	0.9	87,91	45
TGA907	30 x 9	2.7	81	15
TGA907	30 x 9	2.7	91	15
TGA149	30 x 14	0.9	81,83	45

### Aluminium Transition Straight & Formable

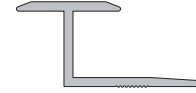

Code	W x D (mm)	Length (m)	Finish	Box Qty
TAG106	17 x 10	2.5	81 Straight	20
TAG106	17 x 10	2.5	91 Straight	20
TAF106	17 x 10	2.5	81 Formable	20
TAF106	17 x 10	2.5	91 Formable	20

### Tile Aluminium Ramp

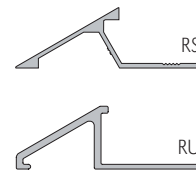

Code	W x D (mm)	Length (m)	Finish	Box Qty
RSA104	20 x 10	2.5	80	20
RSA104	20 x 10	2.5	81	20
RSA124	23 x 12	2.5	80	20
RSA124	23 x 12	2.5	81	20
RUA104	16 x 10	2.5	81,89	20
RUA124	19 x 12	2.5	81,89	20

### Aluminium Access Ramp



Code	W x D (mm)	Length (m)	Finish	Box Qty
RAA104	65 x 10	2.5	81	5
RAA124	65 x 12.5	2.5	81	5
RAA154	90 x 15	2.5	81	5

### Stainless Steel Tile-in Ramp



Code	W x D (mm)	Length (m)	Finish	Box Qty
RSS104	20 x 10	2.5	84	10
RSS124	25 x 12.5	2.5	84	10

### Aluminium Retro-Fit Vinyl Reducer



Code	W x D (mm)	Length (m)	Finish	Box Qty
TVA259	40 x 2.5	0.92	81,83	20
TVA258	40 x 2.5	2.8	81,83	20

### Aluminium Reducer

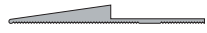
	Code	H (mm)	Length (m)	Finish	Box Qty
	R1931	3	2.7	81	10

### Aluminium Reducer

	Code	H (mm)	Length (m)	Finish	Box Qty
	R2695	2.8	2.7	81	10

### Aluminium Reducer

	Code	H (mm)	Length (m)	Finish	Box Qty
	R2690	5 - 7	2.7	81	10

### Aluminium Reducer

	Code	H (mm)	Length (m)	Finish	Box Qty
	R2650	8	3	81	5

### Aluminium Reducer

	Code	H (mm)	Length (m)	Finish	Box Qty
	RAR157	10.5 - 15	2.7	81	20

### Clip Tops

	Code	W x D (mm)	Length (m)	Finish	Box Qty
TTOP1	TTOP1	53 x 6.25	2.5	16,43	10
TBAS1	TBAS1	34 x 6.25	2.5	80	10
TBAS1	TTOP2	37 x 8.55	2.5	16,43	10
TBAS2	TBAS2	17 x 8.55	2.5	80	10
TBAS2	TTOP3	37 x 8-10	2.5	16,43	10
TBAS3	TBAS3	17 x 8.55	2.5	80	10



### P.V.C. Movement & Perimeter Joint

	Code	D (mm)	Length (m)	Infill Finish	Box Qty
	MLB080	8	2.5	35	30
	MLB100	10	2.5	16,25,35	25
	MLB125	12.5	2.5	16,35	25

### P.V.C. Screed Joint

	Code	D (mm)	Length (m)	Finish	Box Qty
	MSR300	30	2.5	11,16,25	25
	MSR500	50	2.5	11,16,25	25

### Aluminium Intermediate Joint

	Code	D (mm)	Length (m)	Infill Finish	Box Qty
	MMA100	10	2.5	16,35	10
	MMA120	12	2.5	16,35	10

### Stainless Steel Heavy Duty

	Code	D (mm)	Length (m)	Infill Finish	Box Qty
	MHS080	8	2.5	16,35	10
	MHS100	10	2.5	16,35	10
	MHS120	12	2.5	16,35	10
	MHS150	15	2.5	16,35	10
	MHS225	22.5	2.5	16,35	10

### Optimax Stainless Steel Heavy Duty

	Code	D (mm)	Length (m)	Infill Finish	Box Qty
	MSS100	10	2.5	16,35	10
	MSS120	12.5	2.5	16,35	10

## Optimax Aluminium Heavy Duty

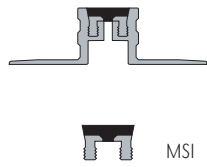

Code	D (mm)	Length (m)	Infill Finish	Box Qty
MSA080	8	2.5	16,35	10
MSA100	10	2.5	16,25,35	10
MSA125	12	2.5	16,25,35	10
MSA150	15	2.5	16,35	10
MSA180	18	2.5	16,35	10
MSA225	22.5	2.5	16,35	10
<b>Optimax Aluminium Heavy Duty Replaceable Infill</b>				
Code	D (mm)	Length (m)	Finish	Box Qty
MSI100	9.8	2.5	16,35	20

## Surface Mounted (wide raised vinyl insert)

**NEW**



<b>Channel</b>				
Code	Length (m)	Finish	Box Qty	
R1851	3	80	10	
<b>Insert (to be ordered separately)</b>				
Code	Depth (mm)	Type	Insert Finish	Box Qty
R6768	3	Smooth	16	10
R6767	3	Smooth	35	10

## Heavy Duty Surface Mounted (wide raised vinyl insert)

**NEW**



<b>Channel</b>				
Code	Length (m)	Finish	Box Qty	
R1860	3	80	10	
<b>Insert (to be ordered separately)</b>				
Code	Depth (mm)	Type	Insert Finish	Box Qty
R6768	3	Smooth	16	10
R6767	3	Smooth	35	10

## Surface Mounted (raised vinyl insert)

**NEW**



<b>Channel</b>				
Code	Length (m)	Finish	Box Qty	
R1851	3	80	10	
<b>Insert (to be ordered separately)</b>				
Code	Depth (mm)	Type	Insert Finish	Box Qty
R6742	3	Smooth	16	10
R6740	3	Smooth	35	10
R6743	3	Grooved	16	10
R6741	3	Grooved	35	10

## Surface Mounted (bevelled edge)

**NEW**

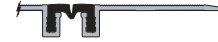

<b>Channel</b>				
Code	Length (m)	Finish	Box Qty	
R1850	3	81	10	
<b>Insert (to be ordered separately)</b>				
Code	Depth (mm)	Type	Insert Finish	Box Qty
R6760	0	Smooth	16	10
R6765	0	Grooved	16	10

## Surface Mounted (raised 5mm vinyl insert)

**NEW**



<b>Channel</b>				
Code	Length (m)	Finish	Box Qty	
R1851	3	80	10	
<b>Insert (to be ordered separately)</b>				
Code	Depth (mm)	Type	Insert Finish	Box Qty
R6747	5	Smooth	16	10
R6745	5	Smooth	35	10
R6748	5	Grooved	16	10
R6746	5	Grooved	35	10

## Heavy Duty Surface Mounted (raised vinyl insert)

**NEW**



<b>Channel</b>				
Code	Length (m)	Finish	Box Qty	
R1860	3	80	10	
<b>Insert (to be ordered separately)</b>				
Code	Depth (mm)	Type	Insert Finish	Box Qty
R6742	5	Smooth	16	10
R6740	5	Smooth	35	10
R6743	5	Grooved	16	10
R6741	5	Grooved	35	10

## Structural Joint Wall Cover, P.V.C.

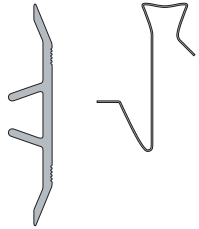

Code	Finish	Width (mm)	Depth (mm)	Length (m)	Box Qty	Fixing
R2873	01	50	4	3	10	Clip
R2872	11	50	4	3	10	Clip
R2871	25	50	4	3	10	Clip
<b>Structural Joint Wall Cover Clip, Stainless Steel</b>						
Code	Finish	Description	Box Qty			
R6876	84	5 per pack	50			

## Structural Joint Cover, Stainless Steel. Self Adhesive



Code	Width (mm)	Depth (mm)	Length (m)	Finish	Box Qty	Side Drill
GC2796	60	5	2.5	102	10	On request
GC2797	80	5	2.5	102	10	On request
GC2798	100	5	2.5	102	10	On request

## Aluminium Covers, Self Adhesive



Code	W x D (mm)	Length (m)	Finish	Box Qty
GC2806	60 x 4	3.4	81	10
GC2820	80 x 4	3	81	10
GC2814	100 x 3	3	81	5
GC2822	120 x 4	3	81	10
GC2819	150 x 5	3	81	1
GC2841	180 x 5	3	81	5

## Aluminium Covers, Screw Fixing & SA on other side



Code	W x D (mm)	Length (m)	Finish	Box Qty
GC2801	60 x 4	3.4	81	10
GC2811	80 x 4	3.4	81	10
GC2815	100 x 3	3.0	81	5

## Aluminium Covers, Plug Fixing (included)



Code	W x D (mm)	Length (m)	Finish	Box Qty
GC2846	80 x 5	3.4	81	10
GC2848	100 x 5	3.4	81	10

## P.V.C. Retro-Fit Corner Protector



Code	W x D (mm)	Length (m)	Finish	Box Qty
ERP120	12 x 12	2.5	01	50
ERP200	20 x 20	2.5	01	50
ERP250	25 x 25	2.5	01	50
ERP300	30 x 30	2.5	01	25
ERP400	40 x 40	2.5	01	25
ERP500	50 x 50	2.5	01	25

## P.V.C. Formable Plaster Protector

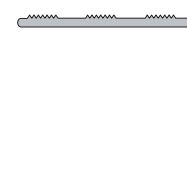

Code	W x D (mm)	Length (m)	Finish	Box Qty
EPF250	25 x 2	2.5	111	50

## Aluminium Retro-Fit Corner Protector

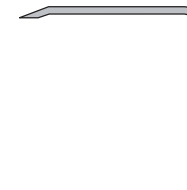

Code	W x D (mm)	Length (m)	Self-Adhesive	Finish	Box Qty
EAA100 <b>NEW</b>	10 x 10	2.5	Yes	81	20
EAA100 <b>NEW</b>	10 x 10	2.5	Yes	91	20
EAA250	25 x 25	2.5	Yes	81	20
EAA254	25 x 25	2.5	No	81	20

## Stainless Steel Retro-Fit Corner Protector - Self Adhesive



Code	W x D (mm)	Length (m)	Finish	Box Qty
EAS154 <b>NEW</b>	15 x 15	2.5	84,102	10
EAS304	30 x 30	2.5	102,84	10
EAS504	50 x 50	2.5	102,84	10
EAS515	50 x 50	1.5	84	10

### Trim Regular



Code	D (mm)	Length (m)	Finish	Box Qty
ETR608	6	2.5	01,11,16,32,34,111	100
ETR708	7	2.5	01	100
ETR808	8	2.5	01,09,10,11,12,14,16 20,25,26,32,34,111	100
ETR808	8	2.5	62,63,64,70,72,116	100
ETR108	10	2.5	01,09,10,11,12,14,15,16 20,25,26,32,34,107 109,111,113	60
ETR108	10	2.5	62,64,70,72,81,91	60
ETR128	12	2.5	01,09,10,11,14,16,25,26 32,34,111	60
ETR128	12	2.5	64,70	60

### Trim Plus

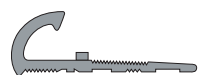

Code	D (mm)	Length (m)	Finish	Box Qty
ETP908	9	2.5	01	50

### Trim Regular Corner Pieces



PR - Double



PD - Single



PE - Large

Code	D (mm)	Type	Finish	Pack Qty
PDM603	6	Single	01,10,11,14,16,25,32,34	100
PDP604	6	Single	01,10,11,14,16,25,32,34	4 Blister Pack
PRM603	6	Double	01	100
PER604	6	Large Double	01,32	50
PDL803	8	Single	01,10,11,14,16,25,32,34	100
PDP804	8	Single	01,10,11,14,16,25,32,34	4 Blister Pack
PRL803	8	Double	01	100
PER804	8	Large Double	01,32	50
PDX103	10	Single	01,10,11,14,16,25,32,34	100
PDP104	10	Single	01,10,11,14,16,25,32,34	4 Blister Pack
PRX103	10	Double	01	100
PDX123	12	Single	01,10,11,14,16,25,32,34	100
PDP124	12	Single	01,10,11,14,16,25,32,34	4 Blister Pack

### Trim Plus Corner Pieces



Code	D (mm)	Type	Finish	Qty / Pack
PCL235	9	Internal/External	01	2 of each

### P.V.C. Internal Trim



Code	D (mm)	Length (m)	Finish	Box Qty
ETI070	7	2.5	01	50
ETI090	9	2.5	01,10,11,14,25,32	50
ETI090	9	2.5	09,15,21,52,107,109,113	50
ETI090	9	2.5	62	50

### P.V.C. Internal Cove & Corners

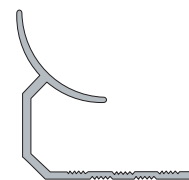

Code	W x D (mm)	Length (m)	Finish	Box Qty
EKI090	15 x 9	2.5	01	25
<b>P.V.C. Internal Cove Corner Pieces</b>				
Code	Description	D (mm)	Finish	Pack Qty
PKE912	External Corner	9 / 12	01	50
PKI912	Internal Corner	9 / 12	01	50

### P.V.C. Square Trim

**NEW**



Code	W x D (mm)	Length (m)	Finish	Box Qty
TPP104	8 x 10	2.5	01,32	60
TPP124	8 x 12	2.5	01,32	60
<b>P.V.C. Square Trim Corner Pieces</b>				
Code	Packed	Finish	Pack Qty	
PTP104	10mm 2 way corner	01,32	4	
PTP124	12mm 2 way corner	01,32	4	

### Straight Edge Trim



Code	D (mm)	Length (m)	Finish	Box Qty
ESP060	6	2.5	01	100
ESP080	8	2.5	01,11,14,32	100
ESP080 <b>NEW</b>	8	2.5	34	100
ESP100	10	2.5	01,11,14,16,32	100
ESP100 <b>NEW</b>	10	2.5	34	100
ESP120	12	2.5	01,11,14,32	100
ESP120 <b>NEW</b>	12	2.5	34	100
ESP150	15	2.5	01	100

### P.V.C. Eezi Seal

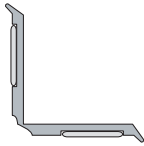

Code	W x D (mm)	Length (m)	Finish	Box Qty
SOR335	15 x 15	3.5	01	48

### P.V.C. Beading



Code	Fixing	Length (m)	Finish	Box Qty
SRP250	Over tile only	2.5	01	25

**P.V.C. Beading Corner Pieces**

Code	Packed	Finish	Box Qty
SRE100	2 way external corner x 5	01	50
SRI100	2 way internal corner x 5	01	50
SRT100	3 way internal corner x 5	01	50

### P.V.C. Seal Under / Over Tile

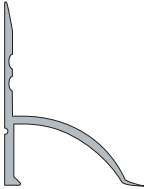

Code	Fixing	Length(m)	Finish	Box Qty
SBS180	Under / over tile	1.8	01	25
SPS180	Under tile only	1.8	01	25

**P.V.C. Seal Under / Over Tile Corner Pieces**

Code	Packed	Finish	Box Qty
SMT100	1 corner + 2 end caps	01	50 packs

### P.V.C. Vinyl to Tile



EFU

Code	W x D (mm)	Length (m)	Finish	Box Qty
EVC080	15 x 8 (punched flange)	2.5	01	25
EVU080	15 x 8 (unpunched flange)	2.5	01	25
EVT080	15 x 8	2.5	01	25
EVT120	15 x 12	2.5	01	25
EFU080	15 x 8	2.5	01	25

### Aluminium Straight Edge Trim



ESA030,040,050



ESA060 onwards

Code	D (mm)	Length (m)	Finish	Box Qty
ESA030	2.25	2.5	80	20
ESA040	3.25	2.5	80	20
ESA050	4.25	2.5	80	20
ESA060	6	2.5	80	20
ESA060	6	2.5	01,81	20
ESA060	6	2.5	91	20
ESA080	8	2.5	80	20
ESA080	8	2.5	01,16,81	20
ESA080	8	2.5	88,91,94	20
ESA080 <b>NEW</b>	8	2.5	101	10
ESA100	10	2.5	80	20
ESA100	10	2.5	01,16,81,85,89	20
ESA100	10	2.5	86,88,91,94	20
ESA100 <b>NEW</b>	10	2.5	101	10
ESA120	12	2.5	80	20
ESA120	12	2.5	01,16,81,85,89	20
ESA120	12	2.5	86,88,91,94	20
ESA120 <b>NEW</b>	12	2.5	101	10
ESA150	15	2.5	80	20
ESA150	15	2.5	81	20
ESA150	15	2.5	91,94	20
ESA180	18	2.5	80	20
ESA180 <b>NEW</b>	18	2.5	81	20
ESA180 <b>NEW</b>	18	2.5	91	20
ESA225	22.5	2.5	80	20
ESA225	22.5	2.5	91	20

Formable

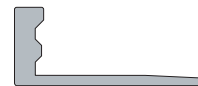

Code	D (mm)	Length (m)	Finish	Box Qty
EFA060	6	2.5	80	20
EFA080	8	2.5	80	20
EFA100	10	2.5	80	20
EFA100	10	2.5	91	20
EFA120	12	2.5	80	20
EFA120	12	2.5	91	20
EFA150	15	2.5	80	20
EFA180	18	2.5	80	20
EFA225	22.5	2.5	80	20

### Aluminium Medium Duty Trim

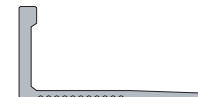

Code	D (mm)	Length (m)	Finish	Box Qty
EMA080	8	2.5	80	20
EMA100	10	2.5	80	20
EMA120	12	2.5	80	20

### Aluminium Square Trim Corners - Internal/External

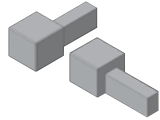

Code	D (mm)	Pack Qty	Finish	Box Qty
EDP080	8	4	81,82,91,94,95,96	20
EDP100	10	4	01,16,81,82,91,94,95,96	20
EDP100	10	4	101	20
EDP120	12	4	01,16,81,82,91,94,95,96	20
EDP120	12	4	101	20
EDP150	15	4	81,91,94	20

### Aluminium Square Trim

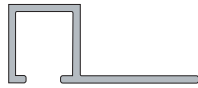

Code	W x D (mm)	Length (m)	Finish	Box Qty
TDP060	10 x 6	2.5	91,94	20
TDP080	10 x 8	2.5	81	20
TDP080	10 x 8	2.5	82,91,94,95,96	20
TDP100	10 x 10	2.5	01,16,81	20
TDP100	10 x 10	2.5	25,34,39,40,41,82,91,94,95,96,401,416,434	20
TDP100	10 x 10	2.5	101	10
TDP120	10 x 12	2.5	01,16,81	20
TDP120	10 x 12	2.5	25,34,39,40,41,82,91,94,95,96,401,416,434	20
TDP120	10 x 12	2.5	101	10
TDP150	10 x 15	2.5	81	20
TDP150	10 x 15	2.5	91,94	20

Formable

Code	W x D (mm)	Length (m)	Finish	Box Qty
TDF084	10 x 8	2.5	91	20
TDF104	10 x 10	2.5	91	20
TDF124	10 x 12	2.5	91	20

### Aluminium Contour Trim & Corners

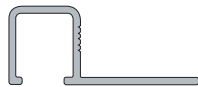

Aluminium Contour Trim				
Code	W x D (mm)	Length (m)	Finish	Box Qty
TDG084	8 x 8	2.5	81	20
TDG084	8 x 8	2.5	91	20
TDG104	10 x 10	2.5	81	20
TDG104	10 x 10	2.5	91	20
TDG124	12 x 12	2.5	81	20
TDG124	12 x 12	2.5	91	20

Aluminium Contour Trim Corner Pieces - External				
Code	D (mm)	Finish	Pack Qty	Box Qty
ECG080	8	81,91	4	4
ECG100	10	81,91	4	4
ECG120	12	81,91	4	4

### Aluminium Slim Trim - Square

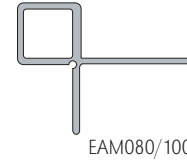

EAM080/100

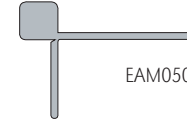

EAM050

Code	W x D (mm)	Length (m)	Finish	Box Qty
EAM050	6 x 5	2.5	91	20
EAM080	9 x 8	2.5	91	20
EAM100	11 x 10	2.5	91	20

### Aluminium Slim Square Edge Trim & Corners

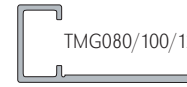

TMG080/100/120



TMG050

Aluminium Slim Square Edge Trim				
Code	D (mm)	Length (m)	Finish	Box Qty
TMG050	5	2.5	81	20
TMG050	5	2.5	91	20
TMG080	8	2.5	81	20
TMG080	8	2.5	91	20
TMG100	10	2.5	81	20
TMG100	10	2.5	91	20
TMG120	12	2.5	81	20
TMG120	12	2.5	91	20

Aluminium Slim Square Edge Trim Internal and External Corners				
Code	D (mm)	Type	Finish	Pack Qty
EMG050	5	Int / Ext	81,91	4
EMG080	8	Int / Ext	81,91	4
EMG100	10	Int / Ext	81,91	4
EMG120	12	Int / Ext	81,91	4

### Aluminium Round Edge & Corners

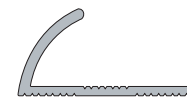

Aluminium Round Edge				
Code	D (mm)	Length (m)	Finish	Box Qty
ERA080	8	2.5	91	20
ERA100	10	2.5	81	20
ERA100	10	2.5	91	20
ERA120	12	2.5	81	20
ERA120	12	2.5	91	20

Aluminium Round Edge Corner Pieces - External			
Code	D (mm)	Finish	Pack Qty
ECA080	8	91	2
ECA100	10	91	2
ECA120	12	91	2

### Aluminium Quadrant Trim

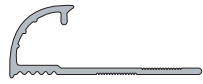

Code	D (mm)	Length (m)	Finish	Box Qty
EAQ060	6	2.5	01,81	20
EAQ060	6	2.5	91	20
EAQ080	8	2.5	80	20
EAQ080	8	2.5	01,16,81,85	20
EAQ080	8	2.5	91,94	20
EAQ090	9	2.5	81	20
EAQ090	9	2.5	91	20
EAQ100	10	2.5	80	20
EAQ100	10	2.5	01,16,81,85	20
EAQ100	10	2.5	25,34,86,91,94	20
EAQ120	12	2.5	80	20
EAQ120	12	2.5	01,16,81,85	20
EAQ120	12	2.5	25,34,86,91,94	20
EAQ150	15	2.5	81	20
EAQ150	15	2.5	91	20

### Aluminium Pro Trim

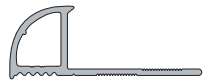

Code	D (mm)	Length (m)	Finish	Box Qty
ETA060	6	2.5	81	20
ETA060	6	2.5	91	20
ETA080	8	2.5	81	20
ETA080	8	2.5	91,94	20
ETA100	10	2.5	81	20
ETA100	10	2.5	91,94	20
ETA120	12	2.5	81	20
ETA120	12	2.5	91,94	20

### Aluminium Pro Trim & Quadrant Trim Corners

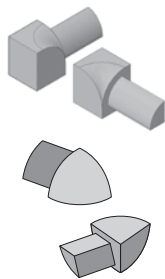

#### Aluminium Quadrant Trim Internal Corners

Code	D (mm)	Type	Finish	Pack Qty
EIQ080	8	Internal	81,91,94	4
EIQ100	10	Internal	81,86,91,94	4
EIQ120	12	Internal	81,86,91,94	4

#### Aluminium Quadrant Trim External Corners

Code	D (mm)	Type	Finish	Pack Qty
ETC060	6	External	81,91	4
EAC060	6	External	91	4
EAC080	8	External	01,16,80,81,91,94	4
EAC100	10	External	01,16,80,81,86,91,94	4
EAC120	12	External	01,16,80,81,86,91,94	4
EAC150	15	External	80,81,91	4

\*Fits ETA060 only  
\*Fits EAQ060 only

### Aluminium Angle Trim & Corners

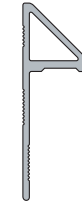

#### Aluminium Angle Trim

Code	W x D (mm)	Length (m)	Finish	Box Qty
EAT080	9 x 8	2.7	81	20
EAT080	9 x 8	2.7	91,94	20
EAT100	11 x 10	2.7	81	20
EAT100	11 x 10	2.7	91,94	20
EAT120	13 x 12	2.7	81	20
EAT120	13 x 12	2.7	91,94	20

#### Aluminium Internal and External Corners

Code	D (mm)	Type	Finish	Box Qty
EET080	8	External	81,91,94	4
EET100	10	External	81,91,94	4
EET120	12	External	81,91,94	4
EIT080	8	Internal	81,91,94	4
EIT100	10	Internal	81,91,94	4
EIT120	12	Internal	81,91,94	4

### Aluminium Self Adhesive Internal Trim, Corners & Caps

**NEW**



#### Aluminium Internal Trim

Code	D (mm)	Length (m)	Finish	Box Qty
EWA150	15	2.5	81	20
EWA150	15	2.5	91	20

#### Aluminium Internal Trim Internal Corner Piece & End Caps

Code	D (mm)	Type	Finish	Pack Qty
EWI150	15	Internal Corner	81,91	2
EWE150	15	External Corner	81,91	2
EWK150	15	End Caps	81,91	2

### Dividing Strips

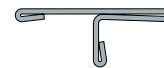

EDS209

#### Aluminium Dividing Strip

Code	W x D (mm)	Length (m)	Finish	Box Qty
EDA510	5 x 10	2.5	80	20
EDA147	14 x 8	2.5	81	20
EDA408	22 x 9	2.5	80	20
EDA408	22 x 9	2.5	81,83	20

#### Stainless Steel Dividing Strip

Code	W x D (mm)	Length (m)	Finish	Box Qty
EDS209	20 x 9	2.5	84	10



### Stainless Steel Straight Edge Trim (304 & 316)



**Stainless Steel Straight Edge Trim - Grade 304**

Code	D (mm)	Length (m)	Finish	Box Qty
ESS045	4.5	2.5	84	10
ESS060	6	2.5	84	10
ESS080	8	2.5	84	10
ESS100	10	2.5	84	10
ESS120	12	2.5	84	10
ESS150	15	2.5	84	10
ESS180	18	2.5	84	10
ESS225	22.5	2.5	84	10

**Stainless Steel Straight Edge Trim - Grade 316**

Code	D (mm)	Length (m)	Finish	Box Qty
ESS310	10	2.5	84	10
ESS312	12	2.5	84	10

**Formable**

Code	D (mm)	Length (m)	Finish	Box Qty
ESF100	10	2.5	84	10
ESF120	12	2.5	84	10

### Stainless Steel Square Edge Trim



Code	D (mm)	Length (m)	Finish	Box Qty
EQS080	8	2.5	84	10
EQS100	10	2.5	84	10
EQS120	12	2.5	84	10

**Stainless Steel Square Trim Corners - Grade 304**

Code	D (mm)	Finish	Box Qty
EQI080	8	84	1
EQI100	10	84	1
EQI120	12	84	1

### Stainless Steel Quadrant Trim & Corners



**Stainless Steel Quadrant Trim - Grade 304**

Code	D (mm)	Length (m)	Finish	Box Qty
ESQ060	6	2.5	84	10
ESQ080	8	2.5	84	10
ESQ100	10	2.5	84	10
ESQ120	12	2.5	84	10

**Stainless Steel Quadrant Trim - Grade 316**

Code	D (mm)	Length (m)	Finish	Box Qty
ESQ308	8	2.5	84	10
ESQ310	10	2.5	84	10
ESQ312	12	2.5	84	10

**Stainless Steel Quadrant Trim Corners - Grade 304**

Code	D (mm)	Finish	Pack Qty
ECQ080	8	84	1
ECQ100	10	84	1
ECQ120	12	84	1

### Flat Line Listello



LFA100

Code	W x D (mm)	Length (m)	Finish	Box Qty
LFA100	10 x 8	2.5	81	20
LFA100	10 x 8	2.5	86,91,94	20
LFA100	10 x 8	2.5	101	20
LFA200	20 x 8	2.5	88,91,94	20
LFA200	20 x 8	2.5	89	20

### Stainless Steel Listello



Code	W x D (mm)	Length (m)	Finish	Box Qty
LPS250	25 x 8	2.5	84,102	10
LPS400	40 x 8	2.5	84	10

### Aluminator™ Listello



Code	W x D (mm)	Length (m)	Finish	Box Qty
ALA100	15 x 10	2.5	81	10

### Aluminium Listello



LPA100

Code	W x D (mm)	Length (m)	Finish	Box Qty
LPA100	10 x 7	2.5	91,94	20
LPA250	25 x 7	2.5	81	20
LPA250	25 x 7	2.5	91,94	20

### Aluminium Clip On Skirting, Corners & End Caps



Code	W x D (mm)	Length (m)	Finish	Box Qty
KAC710	10 x 70	2.5	81	10
<b>Aluminium Clip On Skirting Pre-formed External Corners</b>				
Code	W x D (mm)	Description	Finish	Box Qty
KEC710	10 x 70	Pre-formed external corner	81	1
KIC710	10 x 70	Pre-formed internal corner	81	1
<b>Aluminium Clip On Skirting Professional External Corners</b>				
Code	W x D (mm)	Description	Finish	Box Qty
KEP710	10 x 70	Professional External Corner	81	1
<b>Aluminium Clip On Skirting End Caps</b>				
Code	W x D (mm)	Description	Finish	Box Qty
KLC710	10 x 70	Left end cap	81	1
KRC710	10 x 70	Right end cap	81	1

### Aluminium Skirting, Corners & End Caps

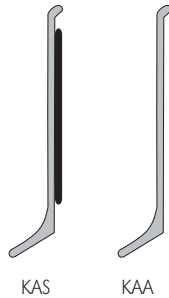

<b>Aluminium Skirting Self Adhesive</b>				
Code	D (mm)	Length (m)	Finish	Box Qty
KAS607	60	2.7	81	10
KAS807	80	2.7	81	10
KAS107	100	2.7	81	10
<b>Aluminium Skirting Standard</b>				
Code	D (mm)	Length (m)	Finish	Box Qty
KAA607	60	2.7	81	10
KAA807	80	2.7	81	10
KAA107	100	2.7	81	10
<b>Aluminium Skirting Corners &amp; End Caps</b>				
Code	Description	Finish	Box Qty	
KLE600	Left end cap for KAA600 / KAS600	81	1	
KRE600	Right end cap for KAA600 / KAS600	81	1	
KES600	External corner for KAA600 / KAS600	81	1	
<b>P.V.C. Skirting Corners &amp; End Caps</b>				
Code	Description	Finish	Box Qty	
KPE600	External Corner for KAA600/KAS600	11	20	
KPI600	Internal Corner for KAA600/KAS600	11	20	
KPC600	Pair End Caps (L/R) for KAA600/KAS600	11	20	
KPE800	External Corner for KAA800/KAS800	11	20	
KPI800	Internal Corner for KAA800/KAS800	11	20	
KPC800	Pair End Caps (L/R) for KAA800/KAS800	11	20	
KPE100	External Corner for KAA100/KAS100	11	20	
KPI100	Internal Corner for KAA100/KAS100	11	20	
KPC100	Pair End Caps (L/R) for KAA100/KAS100	11	20	

### Super Pro Cutter 600mm with Case



Code	Description	Qty
987	Super Pro Cutter 600mm	1
986W	6mm Spare Wheel	1
987W	10mm Spare Wheel	1

### Ultra Flatbed Cutter



Code	Description	Qty
980-750	Ultra Cutter 750mm	1
980-1000	Ultra Cutter 1000mm	1
980-W	Spare Wheel	1

### Tilt Head Tile Saw



Code	Description	Qty
7TH250	Tilt Head Tile Saw	1

### Portable Tile Saw



Code	Description	Qty
7TS180	Portable Tile Saw	1

### Electric Mixer



Code	Description	Qty
930-220V	220V Electric Mixer	1
930P	Spare Paddle for 930	10

### Mixer



Code	Description	Qty
914	400mm x 80mm Mixer	6
913	500mm x 100mm Mixer	10

### Diamond Cutting Wheel - Continuous Rim



Code	Diameter	Bore	Qty
B775115	115	22.2	1
B775125	125	22.2	1
B775180	180	25.4	1
B775200	200	30.0	1
B775250	250	30.0	1
B775300	300	30.0	1

### Diamond Cutting Wheel - Turbo



Code	Diameter	Bore	Qty
B776115	115	22.2	1
B776125	125	22.2	1
B776180	180	25.4	1

### Diamond Cyclone Blades



Code	Diameter	Bore	Qty
B335115	115	22.2	1
B335125	125	22.2	1

### Reducers



Code	Description	Qty
B505374	25.4 to 22.2mm	1
B505376	30 to 22.2mm	1
B505375	30 to 25.4mm	1
B220585	30 to 15.88mm	1

### Diamond Hole Saws



Code	Description	Qty
810	Diamond Hole Saw - 6mm	10
811	Diamond Hole Saw - 8mm	10
812	Diamond Hole Saw - 10mm	10
813	Diamond Hole Saw - 12mm	10
827	Diamond Hole Saw - 18mm	10
870	Diamond Hole Saw - 20mm	10
814	Diamond Hole Saw - 22mm	10
815	Diamond Hole Saw - 27mm	10
816	Diamond Hole Saw - 30mm	10
826	Diamond Hole Saw - 35mm	10
871	Diamond Hole Saw - 42mm	10
872	Diamond Hole Saw - 45mm	10
817	Diamond Hole Saw - 50mm	5
873	Diamond Hole Saw - 55mm	10
874	Diamond Hole Saw - 60mm	10
818	Diamond Hole Saw - 63mm	5
819	Diamond Hole Saw - 75mm	5
875	Diamond Hole Saw - 80mm	10
876	Diamond Hole Saw - 85mm	1
825	Diamond Hole Saw - 115mm	1

### Turbo Dry Drills



Code	Description	Qty
781	6mm	1
782	8mm	1
783	20mm	1
791	<b>NEW</b> 25mm	1
792	<b>NEW</b> 28mm	1
784	35mm	1
785	50mm	1
786	55mm	1
787	60mm	1
788	70mm	1
790	75mm	1

### Dry Drill Bits



Code	Description	Qty
806DD	6mm Dry Drill	10
808DD	8mm Dry Drill	10
810DD	10mm Dry Drill	10
812DD	12mm Dry Drill	10

### Wet & Dry Drill Guide

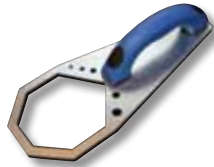

Code	Description	Qty
822	Wet and Dry Drill Guide	6

### Wet & Dry Drill Guide



Code	Description	Qty
824	Universal Guide & Cooler System	1

### 73mm Tri Bore



Code	Description	Qty
830	73mm Tri Bore	20

### Diamond Hand Pads

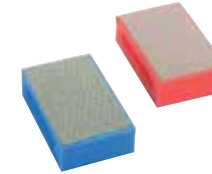

Code	Description	Qty
828F	Fine Diamond Hand Pads	1
828M	Medium Diamond Hand Pads	1

### Tile File Flat & Half Round



Code	Description	Qty
940	Tile File Flat & Half Round	12

### Spacers



Code	Size	Type	Qty	Pack	Box Qty
507	0-7mm	Wedges	100	Bag	10
505	1mm	Cross	500	Bag	50
550	2mm	Cross	100	Bag	50
515	2mm	Cross	250	Bag	25
510	2mm	T Shape	250	Bag	25
544	2mm	Pegs	500	Bag	25
555	2mm	Cross	500	Bag	15
625	2mm	Cross	2500	Bag	2
557	2mm	Cross	5000	Bucket	1
560	2.5mm	Cross	250	Bag	25
535	3mm	Cross	250	Bag	25
536	3mm	Cross	500	Bag	15
630	3mm	Cross	2000	Bag	2
538	3mm	Cross	5000	Bucket	1
540	4mm	Cross	250	Bag	25
542	4mm	Cross	3000	Bucket	1
570	5mm	Cross	100	Bag	50

### Mosaic Mesh



Code	Description	Box
660	Counter top Display Box contents 50 sheets	6

### Mosaic Backing System



Code	Description	Box
605	Mosaic Backing System	50

### Easy Level



Code	Description	Box
664	Large Universal Easy Level Base - Tub of 200 pcs	6
666	Large Easy Level Top - Tub of 100 pcs	6
668	Junior Easy level top - Bag of 100 pcs	6
670	Easy Level Application Tool	10
675	G2 Adjustable Mounting Gun	10
662	Easy Level Starter Pack - 100 Universal Bases & Junior Caps	6

### Square Notch Trowel



Code	Description	Qty
903	3mm Square Notch	6
904	4mm Square Notch	6
906	6mm Square Notch	6
908	8mm Square Notch	6
909	10mm Square Notch	6
907	<b>NEW</b> 12mm Square Notch	6
902	20 x 10mm Round Notch	6

### Notched Tiger Trowel

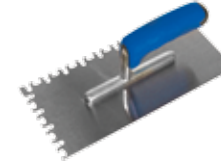

Code	Description	Qty
911TG	Notched Tiger Trowel	10

### Square Notch Trowel



Code	Description	Qty
906SST	6mm Square Notch Stainless Steel	6
909SST	10mm Square Notch Stainless Steel	6

### Softgrip Bucket Trowel



Code	Description	Qty
953	Softgrip Bucket Trowel	12

### Softgrip Gauging Trowel



Code	Description	Qty
952	Softgrip Gauging Trowel	12

### Grout Rake



Code	Description	Qty
925G	Grout Rake	12
925B	Spare Blades for 925G	10

## Grout Float - Universal



Code	Description	Qty
995	Grout Float	12

## Grout Float - Marshalltown



Code	Description	Qty
991	Grout Float - Marshalltown	24

## Duel Edge Float

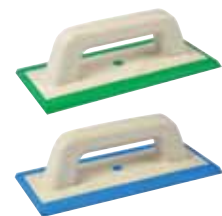

Code	Description	Qty
946BL	Blue Soft Rubber Dual Edge Float	6
946GR	Green Hard Rubber Dual Edge Float	6

## Epoxy Cellulose Sponge Float



Code	Description	Qty
998EXP	Cellulose Sponge Float	6

## Float with Block Cut Sponge

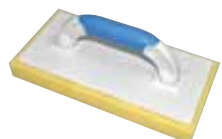

Code	Description	Qty
998	Float with Block Cut Sponge	10

## Float with Hydro Sponge



Code	Description	Qty
998-S	Float with Block Sponge	24
998-SP	Replacement Sponge for 998S	20

## Cleaning Pads



Code	Description	Qty
725-H	80 x 235mm Handle	12
725-BC	Coarse Pad (Black)	100
725-GM	Medium Pad (Green)	100
725-WF	Fine Pad (White)	100
725-FF	Super Fine Pad (White)	100

## Scouring Pad Set



Code	Description	Qty
725SET	Scouring Pad	25

## Sponges



Code	Description	Qty
997	Sml Hydro Sponge (160 x 110 x 50mm)	10
996	Lrg Hydro Sponge (200 x 150 x 60mm)	10
916	Professional Sponge (160 x 110 x 62mm)	100
917	Cellulose Sponge (45 x 120 x 160mm)	60

### Silicone Remover



Code	Description	Qty
864SR	Silicone Remover	12

### Sealant Finishers



Code	Description	Qty
865SF	Sealant Finishers	20

### Caulking Gun



Code	Description	Qty
915	Metal Caulking Gun	6

### Nozzle Stop

**NEW**



Code	Description	Qty
866BP	100 pcs per display carton	6

### Flexi Nozzle

**NEW**



Code	Description	Qty
867FN	Pair of Flexi Nozzles	20

### 23L Wash Boy



Code	Description	Qty
993	23L Washboy	1
993W	4 x Wheels For 993	10
993G	Plastic Grate For 993	10
993R	Rollers For 993	10

### Large Combination Spreader



Code	Description	Qty
954-L	Large Combination Spreader	50

### Squeegee Rubber



Code	Description	Qty
990	Squeegee - 150mm	12

### Pro Floor Squeegee



Code	Description	Qty
708	Floor Squeegee 450mm	10
706	Floor Squeegee 550mm	10
710	Wooden Handle 1500 x 24mm	25

### Compound Nipper



Code	Description	Qty
968	Compound Nipper	10

### Soft Grip Heavy Duty Nipper



Code	Description	Qty
971HD	Heavy Duty Nipper	10

### Soft Grip Universal Nipper



Code	Description	Qty
972	Universal Nipper	10
972W	Spare Wheels for 972 (2pcs)	2

### Trim Mitre Cutter

**NEW**



Code	Description	Qty
973P	Trim Mitre Cutter	6

### Mitre Block



Code	Description	Qty
900MB	Versatile Mitre Box	6

### 5m Tape Measure



Code	Description	Qty
702	Tape Measure	12

### Tile Markers



Code	Description	Qty
704	Tile Markers	25

### Hacksaw



Code	Description	Qty
919PHS	Hacksaw	6
9198LD	Blades	6

### Tile Remover / Scraper



Code	Description	Qty
920TR	Tile Remover / Scraper	12

### Pro Mallet - 16 oz



Code	Description	Qty
901	Professional Mallet - 16 oz	6



### Tile Remover / Scraper



Code	Description	Qty
B869310	Hammer Scraper 250 - 800mm	6
B869311	Spare Blade	10

### Suction Cups



Code	Description	Qty
B334210	Ø 80mm Mini Suction Cup SWL 20kgs	24
B960022	Ø 120mm Aluminium Suction Cup SWL 40kgs	12
B334215	Twin Aluminium Suction Cup SWL 80kgs	6

### G-Flex Timber Floor Reinforcing Sheet

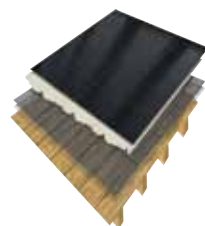

Code	Sheet Size	Pack Area	Pack Qty
GFLEX	600mm x 500mm x 1mm	1.2m <sup>2</sup>	4 sheets

### Tile Magnets for Access Panels



Code	Description	Box
912	Tile Magnets	10

### Magnetic Clip



Code	Description	Qty
712	Magnetic Clip	20

### Knee Pads



Code	Description	Qty
989A	Knee Pads	12

### Foldable Ear Muff



Code	Description	Qty
B205450	Foldable Ear Muff	10

### Work Wipes

**NEW**



Code	Description	Qty
725WW	100 wipes per tub dispenser	20

### Floor Protector



Code	Description	Qty
B869007	Floor Protector	16

### Carpet Protector

**NEW**

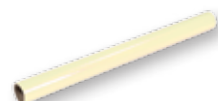

Code	Description	Qty
B869011	Carpet Protector	16

### Cover Blanket



Code	Description	Qty
B776757	Cover Blanket 1 x 5m	6

### Multi Layer Tak Mat 115 x 56cm



Code	Description	Qty
B869010	Tak Mat - 30 sheets per mat	40

### Cover System



Code	Description	Qty
B869001	Dust shield Standard Contains 4 telescopic poles, Clips, Sheeting and 1 Zipper	2
B869002	Aluminium, pole 1,5-3,9m	3
B869003	U-Clips, 12pcs	10
B869004	End-clips, 4pcs	10
B869005	Plastic sheeting 4x5 m	10
B869006	Zipper, 2m	10
B869008	Seal profile, 1,4m	3

### Zipper Door



Code	Description	Qty
8802D	Zipper Door U Shape	10
B869635	Zipper door L shape	5

### Dust Masks



B205454

Code	Description	Qty
B205453	Dust Masks	10
B205454	Dust Masks with Valves	10

### Disposable Earplugs



Code	Description	Qty
B205455	Disposable Earplugs	100

### Safety Glasses



Code	Description	Qty
B205451	Safety Glasses	20

### Basic Cutter 600mm



Code	Description	Qty
984	Basic Cutter 600mm	6
983W	Spare Wheel for 984	100

### Basic Cutter 400mm



Code	Description	Qty
983	Basic Cutter 400mm	9
983W	Spare Wheel for 983	100

### Basic Diamond Hole Saws 2 per pack



Code	Description	Qty
756	2 x 6 mm Hole Saw	20
758	2 x 8 mm Hole Saw	20
760	2 x 10 mm Hole Saw	20

### Basic Diamond Hole Saw Set



Code	Description	Qty
750	Trade Hole Saw Set	10

### Tile / Glass Drill Bits



Code	Description	Qty
836	6mm Tile/Glass Drill Bit	12
838	8mm Tile/Glass Drill Bit	12

### Basic Trowel Range



Code	Description	Qty
966	6mm Square Notch	6
950	6 x 9mm Square Notch	6
951	12mm Square Notch	6

### Plastic Trowel 300 x 140mm



Code	Description	Qty
960	Plastic Trowel	12

### Basic Grout Float



Code	Description	Qty
944	Grout Float - aluminium plate	12

### Float with Sponge - not Block Cut



Code	Description	Qty
998WO	Float with Sponge - not Block Cut	10

### Sponge



Code	Description	Qty
942	Sponge (160 x 110 x 55mm)	100

10L Wash Boy (Catalogue Page 129)



Code	Description	Qty
992	10L Washboy	1

Combination Spreader (Catalogue Page 129)



Code	Description	Qty
954	Combination Spreader	50

Soft Grip Nipper (Catalogue Page 129)



Code	Description	Qty
970	Medium Duty Nipper	10

Mitre Box (Catalogue Page 129)

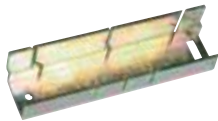

Code	Description	Qty
900	Mitre Box	10

Tile Scriber (Red Cap) (Catalogue Page 129)



Code	Description	Qty
9/1115	Tile Scriber	10

Rodsaw (Catalogue Page 129)



Code	Description	Qty
919P	Professional 6" Rodsaw & Hacksaw	12
926	Pack of 1 Rodsaw Blade	10

Extendable Knee Kicker



Code	Description	Qty
FL3184	Extendable Knee Kicker	1

Hammer Tacker

**NEW**



Code	Description	Qty
FLSM11	Hammer Tacker	1
FLA108P	8mm Staples x 5000	10
FLA110P	9mm Staples x 5000	10

Napping Shears



Code	Description	Qty
FL3020	Napping Shears	1

Stair Tool



Code	Description	Qty
R93840	7cm Stair Tool	1
R93841	9cm Stair Tool	1
FL6374 <b>NEW</b>	9cm Plastic Stair Tool	1

Super Tack Hammer



Code	Description	Qty
FL6080	Super Tack Hammer	1

Clawbar



Code	Description	Qty
FL3116	Clawbar	1

## Smooth Seam Roller

**NEW**

Code	Description	Qty
P63-0614	Smooth Seam Roller	1

## Grooming Roller

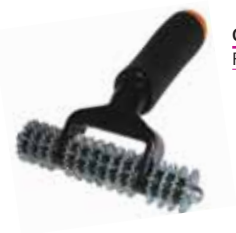
**NEW**

Code	Description	Qty
FL3186	Grooming Roller	1

## Carpet Clamp



Code	Description	Qty
FL3188	Carpet Clamp	1

## Seam Lock

**NEW**

Code	Description	Qty
FL3258	Seam Lock	1

## Pressure Roller

**NEW**

Code	Description	Qty
FL3086	Pressure Roller	1

## Taurex® Knife



Code	Description	Qty
R91115	Taurex® Knife includes 6 Blades and Holster	10

## Genuine Delphin Knife



Code	Description	Qty
R81150	Delphin Knife	10

## Heavy Duty Blades



Code	Description	Qty
R92136	Straight (60mm) Blade x 100	1
R92226	Hook Blade x 100	1
R92236	Super Hook Blade x 100	1
R92126	Straight (50mm) Blade x 100	1
FL3000	Heavy Duty Straight Blades Pack of 100	1
FL3004	Heavy Duty Hook Blades Pack of 100	1
FL3006	Heavy Duty Concave Blades Pack of 100	1

## Shark Knife

**NEW**

Code	Description	Qty
975	Shark Knife	20

## Tin Snips

**NEW**

Code	Description	Qty
FL4034	Tin Snips	1

## Foam Backed Carpet Cutter

**NEW**

Code	Description	Qty
FL3176	Foam Backed Carpet Cutter	1

## Standard Scraper



Code	Description	Qty
R94310	Standard Scraper	1
R92520	Universal Blade 100 x 14mm Pack of 10	10
R92560	Heavy Duty Blade 100 x 18mm Pack of 10	10

## Deluxe Scraper



Code	Description	Qty
FL6368	Deluxe Scraper	1

## Ball Scraper



Code	Description	Qty
FL6372	Ball Scraper	1

## Extension Wall Roller

**NEW**



Code	Description	Qty
FL3340	Extension Wall Roller	1

## Extendable Scraper



Code	Description	Qty
R94380	Mega Scraper Extendable from 99 - 175cm	1
R92530	Spare Blade 20cm x 5 pcs	10

## Industrial Scraper



Code	Description	Qty
R94300	Industrial Scraper	1
R94301	30cm Spare Blade	1

## Spike Shoes



Code	Description	Qty
R94255	Spike Shoes - 40mm	1
R94256	Spike Shoes - 25mm	1

## Spike Roller



Code	Description	Qty
R94241	250 x 11mm Spike Roller with Protector	1
R94242	500 X 11mm Spike Roller with Protector	1
R94239	750 X 11mm Spike Roller with Protector	1
R94246	250 x 31mm Spike Roller with Protector	1
R94248	500 x 31mm Spike Roller with Protector	1

## Interblade Spreader

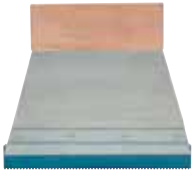

Code	Description	Qty
R94895	280mm Spreader	1

## Interblades



Code	TKB Teeth	Qty
R94898	A1	10
R94900	A2	10
R94904	A4	10
R94906	B1	10
R94909	B3	10
R94917	B9	10
R94918	B11	10
R94919	B15	10

## Trowel Handle & Blades 280 x 110mm

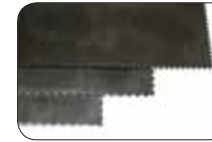

Code	Description	Qty
885H	Trowel Handle	10
8815	Notched Blade 1.5 x 5mm	10
8810	Notched Blade 1 x 4mm	10
8820	Notched Blade 2 x 6mm	10
88A2	Notched Blade A2	10

## Turbo® Dual Blade Trimmer



Code	Description	Qty
R95165	Turbo Dual Blade Trimmer	1
R95167	Set of 2 Spare Blades	1

## Master Turbo® Groover - Patented



Code	Description	Qty
R95200	Master Turbo Groover	1
R95202	Set of 2 Spare Blades	1

## Pico Groover



Code	Description	Qty
R95120	Turbo Dual Blade Trimmer	1
R95176	Set of 10 'U' Spare Blades	1

## P-Type Groover



Code	Description	Qty
FL3082	P-Type Groover	1
FL6000	Set of 10 'U' Spare Blades	1

## Hot Air Gun - Master Turbo

**NEW**

Code	Description	Qty
FL351809	Hot Air Gun with case - 220V	1
FL012601	Hot Air Gun with case - 110V	1

\*Subject to correct usage and maintenance

**10,000 hr  
motor  
life\***

## Hot Air Gun - Turbo

**NEW**

Code	Description	Qty
FL008284	Hot Air Gun	1



## Universal Accessories

**NEW**

Code	Description	Qty
FL010263	3mm Fast weld fits 5mm Nozzle	5
FL010287	5mm Fast weld fits 5mm Nozzle	5
FL075316	5mm Fast weld fits 10mm Nozzle	5
FL092313	10mm Round Nozzle	5
FL092214	5mm Round Nozzle	5



## Mozart Trimming Knife



Code	Description	Qty
R95130	Mozart Trimming Knife	1
R95129	Pack of 5 Spare Blades	1
R95128	0.5mm Trimmer Guide	1
R95127	0.7mm Trimmer Guide	1

## Multi Purpose Groover



R95162

Code	Description	Qty
R95160	Multi Purpose Groover with Rounded Blade R95161	1
R95161	Ø 6mm Rounded Blade x 2	1
R95162	Ø 12mm Rounded Blade x 2	1
R95163	Flat Blade x 2	1
R95164	Pointed Blade x 2	1

## Tucking Knife

**NEW**

Code	Description	Qty
P63-0623	Tucking Knife	6

## Trimming Guide



Code	Description	Qty
FL3038	Trimming Guide	10

## Quarter Moon Knife



Code	Description	Qty
FL3044	Quarter Moon Knife	6
FL3336	Leather Pouch	6



## High-Tech Trimmer



Code	Description	Qty
R91410	High-Tech Trimmer	6
R92416	Set of 100 Spare Blades	1

## Provinyl Edge Trimmer



Code	Description	Qty
R95510	Provinyl Edge Trimmer	1
R95512	Pair Spare Blades Ø 40mm	1

## Carpet & Vinyl Trimmer



Code	Description	Qty
R91400	Carpet and Vinyl Trimmer	12
R92416	Set of 100 Spare Blades	1

## T Square Convex Steel Ruler



Code	Description	Qty
R91571	T Square Convex 4.05m	1
R91538	T Square Convex 2.10m	1

## Adjustable Straight Edge



Code	Description	Qty
R91550	Adjustable Straight Edge	1

## Heat Iron

**NEW**



Code	Description	Qty
FL3220	Heat Iron 230V	1

## Heat Bond Tape

**NEW**



Code	Description	Qty
FL6004	Heat Bond Tape - Gold	1

## Heat Kit

**NEW**



Code	Description	Qty
FL3222	Heat Kit Case	1

## Linoleum Rollers



Code	Description	Qty
R93161	35 kg - Total width 37cm	1
R93160	50 kg - Total Width 52cm	1
R93164	75 kg - Total Width 38cm - Ø 180mm	1

### Z103 1m Maxi Stand



Code	Description	Qty
Z103	1m Genesis Display	1
Z112	Euro Hooks (double prong)	10

### Z100 Mini Stand



Code	Description	Qty
Z100	Tool Stand	1
Z112	Euro Hooks (double prong)	10

### Z110 1m Deluxe Stand



Code	Description	Qty
Z110	Lean back Display Unit	1
Z112	Euro Hooks (double prong)	10

### Transition Stand



Code	Description	Qty
Z015	Transitions Stand	1

### Portable Display Unit



Code	Description	Qty
Z135	Portable Display Stand	1

### Display Modules



Code	Description	Qty
Z123	Display Module	1

Sample Cases



Code	Description	Qty
Z751	Genesis Flooring Sample Case	1

Sample



Code	Description	Qty
Z650	Complete Sample System contains all sample sets	12
Z630-C	P.V.C. Trim Colours Sample Box	1
Z630-F	P.V.C. Trim Fails Sample Box	1
Z631	EAQ Sample Box	1
Z632	Listello Sample Box	1
Z633	Movement Joint Sample Box	1
Z634	Stair Nosing Sample Box	1
Z636	Skirting Sample Box	1
Z644	Ramps Sample Box	1
Z645	Seals Sample Box	1
Z646	Straight Edge Sample Box	1
Z647	Edge Protection Sample Box	1

Samples Boards



Code	Description
Z890	Metal Trim Samples Board A3 (1)
Z891	Nosing Samples Board A3
Z892	Expansion Joints Samples Board A3
Z893	Ramps Samples Board A3
Z894	Skirting Samples Board A3
Z895	PVC Trim Samples Board A3
Z896	Edge Protection Samples Board A3
Z897	Metal Trim Samples Board A3 (2)
Z898	Metal Trim Samples Board A3 (3)
Z899	Wood Effects Samples Board A3
Z888	Triangular POS Board

Catalogue & Price Lists



Code	Description	Qty
Z313	Genesis Catalogue	50
Z312	Genesis Price List	50
Z405	Contract Flooring Price List	50

2016 Desk Calendar



Code	Description	Qty
ZCALENDAR	2016 Desk Calendar	

Wall Chart



Code	Description
Z324	Wall Chart (A1)

Note Pads



Code	Description
Z602	A4 Note Pad
Z501	A6 Note Pad
Z801	Pen

Pen



Code	Description
Z801	Pen

Mugs



Code	Description
Z802	Insulated Travel Mug
Z803	Mug

## Stair Nosings

### Channels - P.V.C.



### Channels - Aluminium

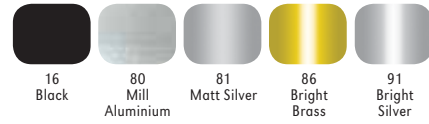

### Standard Inserts

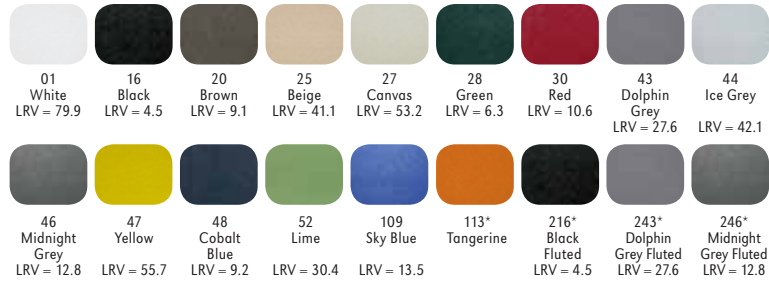

### External Inserts for NHD Range



### Definer Riser



### Genstep+ and NTEX Range Inserts

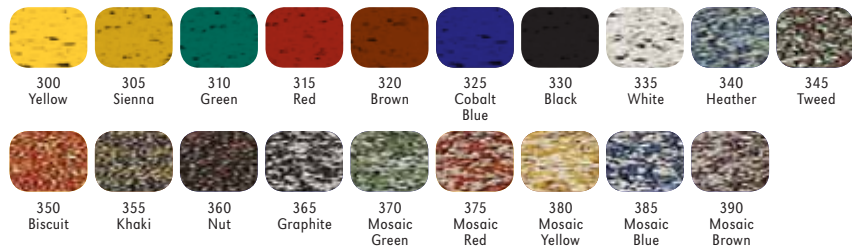

### Genstep

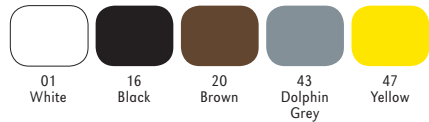

### Tactiles

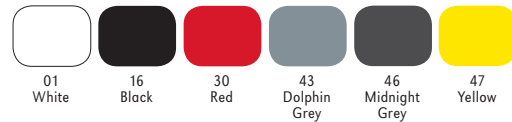

### Tedsafe

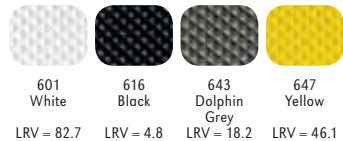

## P.V.C. Flexibles

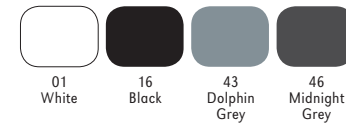

## Transitions



## P.V.C. Trim



## Metal Trim



\* Slimline only. \*\*Stainless Steel Material Only

AHD	15 & 17 & 20	FASD	23	NHD	11-13 & 17-18	R269	34
ALA	49	FTCA	23	NHP	19	R305	22
ALM	24	FTCD	23	NIB	25	R425	22
ATC	19	FTNCD	23	NIFL	18	R610	30
CAS	31	FTNHD	23	NISL	17	R611	30
EAA	39	FTNYA	23	NIITR	18	R674	36 & 37
EAC	46	FTSCA	23	NLC	25	R676	36 & 37
EAM	45	FTSCD	23	NLM	24	R676	36 & 37
EAQ	46	FTSCD	23	NLT	25	R800	29
EAS	39	FTSSA	23	NRA	24	R803	28
EAT	47	FTSSA	23	NRE	24	R882	29
ECA	45	FTSSD	23	NRP	19	R884	29
ECG	44	GC2	38	NSA	18	R890	28
ECQ	48	KA	50	NSB	19	R891	28
EDA	47	KAC	50	NSL	13	R892	28
EDA	47	KAS	50	NSL	16 & 17	R893	28
EDP	44	KCOV	26	NSL	20	R895	28
EDS	47	KCS	27	NSP	19	RAA	33
EET	47	KEC	50	NSR	19	RAR	34
EFA	43	KEP	50	NSS	25	RDIM	27
EFU	42	KES	50	NTC	19	RSA	33
EIQ	46	KIC	50	NTCH	20	RSS	33
EIT	47	KLC	50	NTDC	20	RUA	33
EKI	41	KLE	50	NTEX	21	SOR	42
EMA	43	KPC	50	NTPA	22	TAF	33
EMG	45	KPE	50	NTPD	22	TAG	33
EPF	39	KPI	50	NTPP	22	TAS	31
EQJ	48	KRC	50	NTRD	20	TAV	31
EQS	48	KSI100	26	NTSQ	20	TBA	31
ERA	45	KSO	26	NUC	25	TBAS	34
ERP	39	LFA	49	PCL	40	TCA	31
ESA	43	LPA	49	PDL	40	TCC	32
ESF	47	LPS	49	PDM	40	TCG	32
ESP	41	MHS	35	PDP	40	TCR	32
ESQ	48	MLB	35	PDX	40	TCS	32
ESS	48	MMA	35	PER	40	TDF	44
ETA	46	MSA	36	PKE	41	TDG	44
ETI	41	MSI	36	PKI	41	TDP	44
ETP	40	MSR	35	PRL	40	TGA	32
ETR	40	MSS	35	PRM	40	TMG	45
EVC	42	NAS	23	PRX	40	TPP	41
EVT	42	NAS	31	R106	32	TTB	31
EVU	42	NAT	25	R185	36 & 37	TTG	32
EWA	47	NDEF	21	R186	36 & 37	TTOP	34
EWC	47	NFA	24	R193	34	TVA	33
EWE	47	NFL	22	R206	32		
EWI	47	NHB	19	R265	34		

Adjustable Straight Edge	80	Grout Rake	57	Scouring Pad Set	59
Ball Scraper	74	Hacksaw	63	Sealant Finishers	60
Carpet & Vinyl Trimmer	80	Hammer Tacker	71	Seam Lock	72
Carpet Clamp	72	Heat Bond Tape	81	Silicone Remover	60
Carpet Protector	66	Heat Iron	81	Soft Grip Heavy Duty Nipper	62
Caulking Gun	60	Heat Kit	81	Soft Grip Nipper	70
Clawbar	71	High-Tech Trimmer	80	Soft Grip Universal Nipper	62
Cleaning Pads	59	Hot Air Gun	78	Spacers	55
Combination Spreader	61 & 70	Industrial Scraper	75	Spike Roller	76
Compound Nipper	62	Interblade Spreader	76	Spike Shoes	76
Cover Blanket	66	Knee Pads	65	Sponges	59 & 69
Cover System	66	Knife - Genuine Delphin	73	Squeegee Rubber	61
Cutter - Basic	68	Knife - Heavy Duty Blades	73	Stair Tool	71
Cutter - Super Pro	51	Knife - Quarter Moon	79	Standard Scraper	74
Cutter - Ultra Flatbed	51	Knife - Shark	73	Suction Cups	64
Deluxe Scraper	74	Knife - Taurex®	73	Super Tack Hammer	71
Diamond Cutting Wheel	52	Knife - Tucking	79	T Square Convex Steel Ruler	80
Diamond Cyclone Blades	53	Magnetic Clip	64	Tape Measure	63
Diamond Hand Pads	55	Master Turbo® Groover	77	Tile / Glass Drill Bits	68
Diamond Hole Saws	53	Mitre Block	62	Tile File Flat & Half Round	55
Diamond Hole Saw Set - Basic	68	Mitre Box	70	Tile Magnets	64
Disposable Earplugs	67	Mixer	52	Tile Markers	63
Drill Guide	54	Mosaic Backing System	56	Tile Remover / Scraper	63 - 64
Dry Drill Bits	54	Mosaic Mesh	56	Tile Scriber	70
Dust Masks	67	Mozart Trimming Knife	79	Tilt Head Tile Saw	51
Easy Level	56	Multi Layer Tak Mat	66	Tin Snips	73
Electric Mixer	52	Multi Purpose Groover	79	Tri Bore	55
Extendable Knee Kicker	71	Napping Shears	71	Trim Mitre Cutter	62
Extendable Scraper	75	Nozzle Stop	60	Trimming Guide	79
Extension Wall Roller	75	P-Type Groover	77	Trowel - Basic	69
Flexi Nozzle	60	Pico Groover	77	Trowel - Bucket	57
Float - Block Cut Sponge	58	Plastic Trowel	69	Trowel - Gauging	57
Float - Duel Edge	58	Portable Tile Saw	51	Trowel - Notched Tiger	57
Float - Epoxy Cellulose Sponge	58	Pro Floor Squeegee	61	Trowel - Square Notch	57
Float - Hydro Sponge	59	Pro Mallet - 16 oz	63	Trowel - Square Notch	56
Float with Sponge	69	Provynyl Edge Trimmer	80	Trowel - Handle & Blades	77
Floor Protector	66	Reducers	53	Turbo Dry Drills	54
Foam Backed Carpet Cutter	73	Rodsaw	70	Turbo® Dual Blade Trimmer	77
Foldable Ear Muff	65	Roller - Grooming	72	Universal Accessories	78
G-Flex	64	Roller - Linoleum	81	Wash Boy 10L	70
Grout Float - Basic	69	Roller - Linoleum	81	Wash Boy 23L	61
Grout Float - Marshalltown	58	Roller - Smooth Seam	72	Work Wipes	65
Grout Float - Universal	58	Safety Glasses	67	Zipper Door	67

## Definitions

In these Terms and Conditions the following expressions will have the following meanings unless inconsistent with the context:

“Buyer”	the person(s), firm or company whose order for the Goods is accepted by the Company
“Company”	Genesis Global Systems at Stokesley Business Park, Stokesley, North Yorkshire, TS9 5JZ
“Contract”	any contract between the Company and the Buyer for the sale and purchase of the Goods or supply of the Services formed in accordance with Condition 2
“Delivery Point”	the place where delivery of the Goods is agreed to take place
“Goods”	any Goods which the Company supplies to the Buyer (including any of them or any part of them)
“Terms and Conditions”	the standard terms and conditions of sale set out in this document together with any special terms agreed in writing between the Buyer and the Company

## Formation and Incorporation

The Contract will be upon these Terms and Conditions, to the exclusion of all other terms and conditions and all previous oral or written representations including any terms or conditions which the Buyer purports to apply under any purchase order, confirmation of order or similar document is referred to in the Contract.

Each order or acceptance of a quotation for Goods will be deemed to be an offer by the Buyer and to purchase Goods upon these Terms and Conditions. The Contract is formed when the Buyer receives confirmation that the order is accepted by the Company. No contract will come into existence until such confirmation has been given by the Company.

Quotations are subject to an acceptance period of 45 days from the date of quotation.

The Buyer must ensure that the terms of its order are complete and accurate.

Acceptance of delivery of the Goods will be deemed as conclusive evidence of the Buyer’s acceptance of these Terms and Conditions. The Buyer may not cancel the Contract. The Company may cancel the Contract at any time prior to delivery.

## Price and Payment

The price for the Goods will be the price set out in the Company’s published price list current at the date of delivery or as otherwise notified by the Company to the Buyer prior to the Contract being made. Orders are exclusive of any costs of carriage, packing, insurance and VAT unless otherwise agreed by the Company. A separate export price list may apply for Goods supplied for export from the United Kingdom. Where recommended selling prices are listed these should be treated as a guide.

Where an order is received for quantities less than those quoted or where delivery is required in instalments smaller than those specified in the quotation, then prices may be subject to increase.

The Company may invoice the Buyer for the Goods on or at any time after dispatch. Subject to clause 3.3, payment of the price and VAT shall be due within 30 days of the invoice. Time for payment will be of the essence.

The Company may accept payment on a pro-forma basis providing this arrangement is agreed in writing and signed by a director of the Company.

No payment will be deemed to have been received until the Company has received cleared funds.

All payments to be made by the Buyer under the Contract will be made in full without any set-off, restriction or condition and without any deduction for or on account of any counterclaim. No disputes that may arise under the Contract or delays beyond the reasonable control of the Company shall constitute a reason for interference with prompt payment in full by the Buyer.

If any sum payable under the Contract is not paid when due then, without prejudice to the Company’s other rights under the Contract, the sum will bear interest from the due date until payment is made in full, both before and after any judgment, at 5 per cent per annum over the Bank of England base rate from time to time and the Company will be entitled to suspend deliveries of the Goods until the outstanding sum has been received.

The Company reserves the right to recoup any sum, resulting from costs incurred legal proceedings to recover the sum payable under the Contract.

Any invoice queries must be communicated to the Company within 10 working days of receipt of the invoice by the Buyer.

## Instalments

The Company may deliver the Goods by separate instalments. Each instalment will be a separate Contract and no cancellation or termination of any one Contract relating to an instalment will entitle the Buyer to repudiate or cancel any other Contract or instalment unless otherwise notified by the Company. Each separate instalment will be invoiced and paid for in accordance with the provisions of the Contract.

## Delivery

The Company will use reasonable endeavours to deliver each of the Buyer’s orders for the Goods in accordance with the delivery estimate provided by the Company at the Delivery Point, but the time of delivery will not be of the essence. If, despite those endeavours, the Company is unable for any reason to fulfil any delivery on a specified date, the Company will be deemed not to be in breach of Contract, nor (for the avoidance of doubt) will the Company have any liability to the Buyer for direct, indirect or consequential loss howsoever caused (including as a result of negligence) by any delay or failure in delivery.

Where the Goods are handed to a carrier for carriage to the Buyer or to UK port for export, any such carrier shall be deemed to be an agent of the Company and not the Buyer for the purposes of 43, 44 and 45 of the Sale of Goods Act 1979 (as amended).

No liability will attach to the Company for non-delivery, loss or damage to Goods prior to delivery unless claims to that effect are notified in writing by the Buyer to the Company within four days of delivery and where carriers not of the Company have been used for delivery a copy is delivered to said carrier.

Where delivery is made by a carrier to the Buyer the Buyer is responsible for counting as received, complete or otherwise, the number of outer cartons of Goods documented by the carrier as being delivered. Any shortage should be notified to the Company without delay.

Subject to Condition 5.1, the Company will require the receipt of an order from a Buyer prior to 12.30pm to deliver Goods the following day in the United Kingdom (excluding Northern Ireland).

Minimum order value £175.00 free UK mainland delivery.

## Risk/Title of Goods

Risk of damage to or loss of the Goods will pass to the Buyer in accordance with Condition 5.

Ownership of the Goods will not pass to the Buyer until the Company has received in full all sums due to it in respect of the Goods.

Until ownership of the Goods has passed to the Buyer, the Buyer must:

- hold the Goods on a fiduciary basis on behalf of the Company;
- store the Goods (at no cost to the Company) separately from all other Goods of the Buyer or any 3rd party in such a way they remain readily identifiable;
- not destroy, deface, or obscure any identifying mark or packaging on or relating to the Goods; and
- maintain the Goods in a satisfactory condition insured on the Company’s behalf for their full price against all risks to the reasonable satisfaction of the Company, and will whenever requested by the Company produce a copy of the policy of insurance.

If the Buyer sells or disposes of the Goods to a third party before the sum due to the Company is paid in full then any proceeds resulting there from shall belong to the Company to the extent of the sums owing by the Buyer.

Where the Company (or its appointed carrier) delivers the Goods, the risk shall pass to the Buyer upon delivery. In all other cases, the risk shall pass to the Buyer when the Goods leave the Company’s premises.

The Buyer’s right to possession of the Goods will terminate immediately if any of the circumstances set out in Condition 9 occur.

If payment is overdue in whole or in part the Company may (without prejudice to any of its other rights) recover or resell the Goods or any part thereof and may enter upon the Buyer’s premises by its servants or agents for the purpose.

Nothing in this clause shall confer any right upon the Buyer to return the Goods sold hereunder or to refuse or delay payment therefore.

## Liability of Company

The Company shall not be liable for any costs, claims, damages or expenses arising out of any tortious act or omission or breach of contract or statutory duty calculated by reference to profits, income, production accruals, or by reference to accrual of such costs, claims, damages or expenses on a time basis.

The liability of the Company to the Buyer for any loss of whatsoever nature and howsoever caused shall be limited to and shall in no circumstances exceed the price of the Goods

In no circumstances shall the Company be liable for any cost claim damage or expense resulting from any failure to use the Goods other than for the purpose for which they are supplied by the Company or resulting from any failure to follow any instructions issued by the Company in respect of the Goods.

Each of the provisions of these Conditions of Sale (including each provision providing for the limitation or exclusion of liability) shall be deemed to be fully severable so that if any provision is found to be void in law, whether because it is found to be unreasonable or otherwise, the remainder of the provisions shall continue in full force.

## Intellectual property

No right or licence is granted to the Buyer in respect of the Intellectual Property Rights of the Company, except the right to use, or re-sell the Goods in the Buyer’s ordinary course of business.

The Buyer will not without the Company’s prior consent allow the Company’s marks or words applied to the Goods to be obliterated, obscured or omitted nor will he add any additional marks or words.

Unless paid for in full, any display stand provided by the Company shall remain the property of the Company and will be given on loan or hire to the Buyer to enable effective merchandising of the Goods and it is the Buyer’s responsibility that only the Goods can be displayed or placed on the display stand in any event.

The Buyer will not, without written consent of the Company, use, give away or loan any photographs or documents of confidential records provided to the Buyer by the Company.

## Insolvency or Default of Buyer

If the Buyer shall make default in, or commit any breach of, the Contract or of any other of his obligation to the Company or if any distress or execution shall be levied upon the Buyer’s properly or assets or if the Buyer shall make an offer to make any arrangement for composition with creditors or commit any act of bankruptcy or if any petition or receiving order in bankruptcy shall be presented or made against him or if the Buyer is a Limited Company and any resolution or petition to wind up such company’s business (other than for the purpose of amalgamation or reconstruction) shall be passed or presented or if a receiver of such company’s undertaking property or assets or any part thereof shall be appointed, the Company shall have the right forthwith to determine any contract then subsisting and upon written notice of such determination being posted to the Buyer’s last known address any subsisting Contract shall be deemed to have been determined without prejudice to any claim or right the Company may otherwise make or exercise.

## Export Terms

Where goods are supplied for export from the United Kingdom the following clauses shall (subject to any terms agreed in writing between the Company and the Buyer) apply notwithstanding any other provisions of these Conditions:

- the Buyer shall be responsible for complying with any legislation or regulations governing the importation of the Goods into the country of destination and for the payment of duties on them
- unless otherwise agreed in writing between the Company and the Buyer from the time of dispatch of the Goods from the Company’s premises the Goods shall be at risk of the Buyer and the Company shall be under no obligation to give notice under Section 32(3) of the Sale of Goods Act 1979 (as amended).

## Force Majeure

The Company will not be liable to the Buyer for any failure or delay or for the consequence of any failure or delay in performance of the Contract, if it due to or beyond the reasonable control of the Company including, without limitation, acts of God, war, industrial disputes, protests, fire, tempest, explosion, an act of terrorism and national emergencies and the Company will be entitled to a reasonable extension of time for performing such obligations in such circumstances.

## Legal

Any dispute or difference between the parties arising out of the Contract shall first be referred to mediation in accordance with the procedure of IDR Europe Limited and if the parties cannot agree on a mediator either of them may apply to IDR Europe Limited to appoint a mediator. If the parties fail to reach agreement on the dispute within 60 days of the appointment of the mediator the dispute may be referred to the Courts of England and Wales.

The Contract shall in all respects be governed by English Law and shall be deemed to have been made in England and the Buyer and the Company agree (subject to the provisions of clause 34 above) to submit to the exclusive jurisdiction of the English Courts.

## WEEE Collections Policy

The B23 end user is responsible for all the liabilities regarding the environmentally sound disposal of the EEE when it becomes WEEE, the compliance statements are on the product packaging.

The producer has paid no charge to its PCS (producer compliance scheme) for its eventual recovery. However the PCS’s disposal contractor is able to provide a cost effective and environmentally sound disposal of all 13 categories of WEEE.

For more information contact Genesis today

Tel: +44 (0)1642 713000 Email: [info@genesis-gs.com](mailto:info@genesis-gs.com)  
[www.genesis-gs.com](http://www.genesis-gs.com)



Genesis Global Systems Ltd  
Stokesley Business Park  
Stokesley North Yorkshire TS9 5JZ

